



Solartechnik
Zubehör



Contents

02	The Company
03	Cabur, connected and safe... in all circumstances
04	Cabur Solar. A range of solutions for system connection and protection
05	Cabur Solar Fix
05	Support brackets for anchoring photovoltaic panels
06	Multiplies the possibilities for application
07	Accessories
08	Many advantages and 30% savings
10	Recommendations for proper use
13	Cabur Solar connectors
13	For connection with the most common inverters and junction boxes
14	Composition and materials
16	Electrothermal tests
17	Line 3
22	Cabur Solar Y connectors
23	Line 4
24	Accessories
25	Joint with MC connectors
26	Solarlok® connectors
30	Connection to connectors
31	Tools
31	For perfect photovoltaic connections
32	Matrices for UMCT3149 crimpers
33	Recommendations for proper use
35	First installation kit
36	Wires
37	Technical characteristics of FG21M21 IMQ certified wires
38	Technical characteristics of PV1-F wires
39	StringBox. Connection panels for photovoltaic panel strings
40	Standard StringBox with fuses on both poles for earth insulated panels
41	Standard StringBox with fuse on the positive pole with earthed negative
42	SPDBox. Connection panels downstream of the inverter
43	Surge Protection Devices
43	For PV systems and DC voltage
45	DC
46	AC
48	Modular AC surge protection devices
49	Components for String Boxes Accessories and spare parts
49	Boxes for distribution panels
51	Screw clamp terminal blocks
51	1kV DC insulation
52	Nominal voltage 1000 DC
55	Disconnectors
56	QBLOK terminal boards with 2 poles
56	Distribution terminal board
57	Accessories
58	Fuse holders and fuses to protect the strings
59	Diodes for photovoltaic panel strings
60	Control terminal board
60	UTF for measurement through manoeuvres on TA and TV
61	MCM Series
64	MCT/SA Series
66	Cast resin joints
67	CGG junction boxes
68	Code index

The Company

Founded in 1952, Cabur quickly gained the lead position **among national constructors of terminal boards for electric panels**, pursuing a strategy that placed special focus on installers' needs, as well as proposing cutting edge technological solutions, which in time became generalised applications. Above all, it was ahead of its time in the qualitative choices for its products, especially regarding raw materials, as well as guaranteed functioning, reliability over time and respect for the environment.

All of this allowed Cabur to obtain **Class 1E Qualification** (Equipment for Nuclear Power Generating Stations) in 1985, as well as **ISO 9001 Certification** (Quality) and **ISO 14001** (Environment), and finally, certification of conformance to the ATEX Directive for "**Ex e**" installations on main terminal board lines.

In 2006, Cabur acquired a new advanced production site, which stretches over an area of 15,000 m² in the town of Altare (SV). The extra surface space and a simultaneous increase in personnel allowed for rationalising and rendering even more efficient the production processes, as well as the logistics and sales activities.

Present production, which is wide and diversified, represents the optimal synthesis of Cabur's long experience as a supplier to the main national energy boards and companies, together with activities and collaboration abroad. Today



UNI EN-ISO 9001



UNI EN-ISO 14001

Cabur **develops and produces, using its own designs**, a vast range of products for the electro-technical and electronics industries, products that are famous for their reliability even in extreme working conditions, and that are created to offer optimal solutions for the various and complex installation needs of their users.

The offer includes:

- a line of **terminal blocks** for electrical cabinets and panels, designed to satisfy the fundamental requirements of the most severe installation conditions.
- **power supplies** and **electronic products** for electrical panels, for plant automation, machine automation, and process control.
- a wide range of items for the completion of **connections** for civil installations.
- a line of products for the **connection** and protection of **photovoltaic systems**.
- a line of products and solutions for **industrial marking**.

For documentation on our products, we invite you to register at our company site **www.cabur.it**. You can request all our publications, receive invitations to trade fairs where Cabur is present, and receive a periodic newsletter by e-mail.



Cabur

Connected and safe... in any circumstances

The choice of connection systems is one of the critical factors on which the effective performance of the plant, its efficiency over time and its useful lifetime depend.

To maximise and guarantee efficiency over time, Cabur offers a **range of solutions that guarantee connections that conform** to the highest standards on the market.

From Cabur's offerings, installers can choose the right **connectors** for the technical features of the system and the specifications of the modules and inverters available on the market or already installed.

It is very simple to choose the best solution:

- for combination with the most common inverters/junction boxes, Cabur offers the Cabur Solar line, which includes connectors for PIN diameters (3 or 4 mm) identified by the "Line 3" or "Line 4" name;
- for connection with Tyco Electronics inverters/junction boxes, Cabur offers its Solarlok® connectors, for which it is the authorised dealer.

Both product families are excellent for joining photovoltaic wires and include a complete connection set, with wires, tools and accessories, as well as an ideal First Installation Kit.

To guarantee safety, duration over time and maximum efficiency of the system, Cabur also offers selected products and components, such as:

- **anchorage brackets** for photovoltaic panels;
- a variety of **String Boxes** conforming to safety standards;
- **surge protection devices**;
- **screw clamp terminal blocks**;
- **control terminal board**;
- **diodes**;
- **disconnectors**;
- **fuse holders**;
- **boxes** and other **components** for **distribution panels**.



Cabur Solar

A range of solutions for system connection and protection

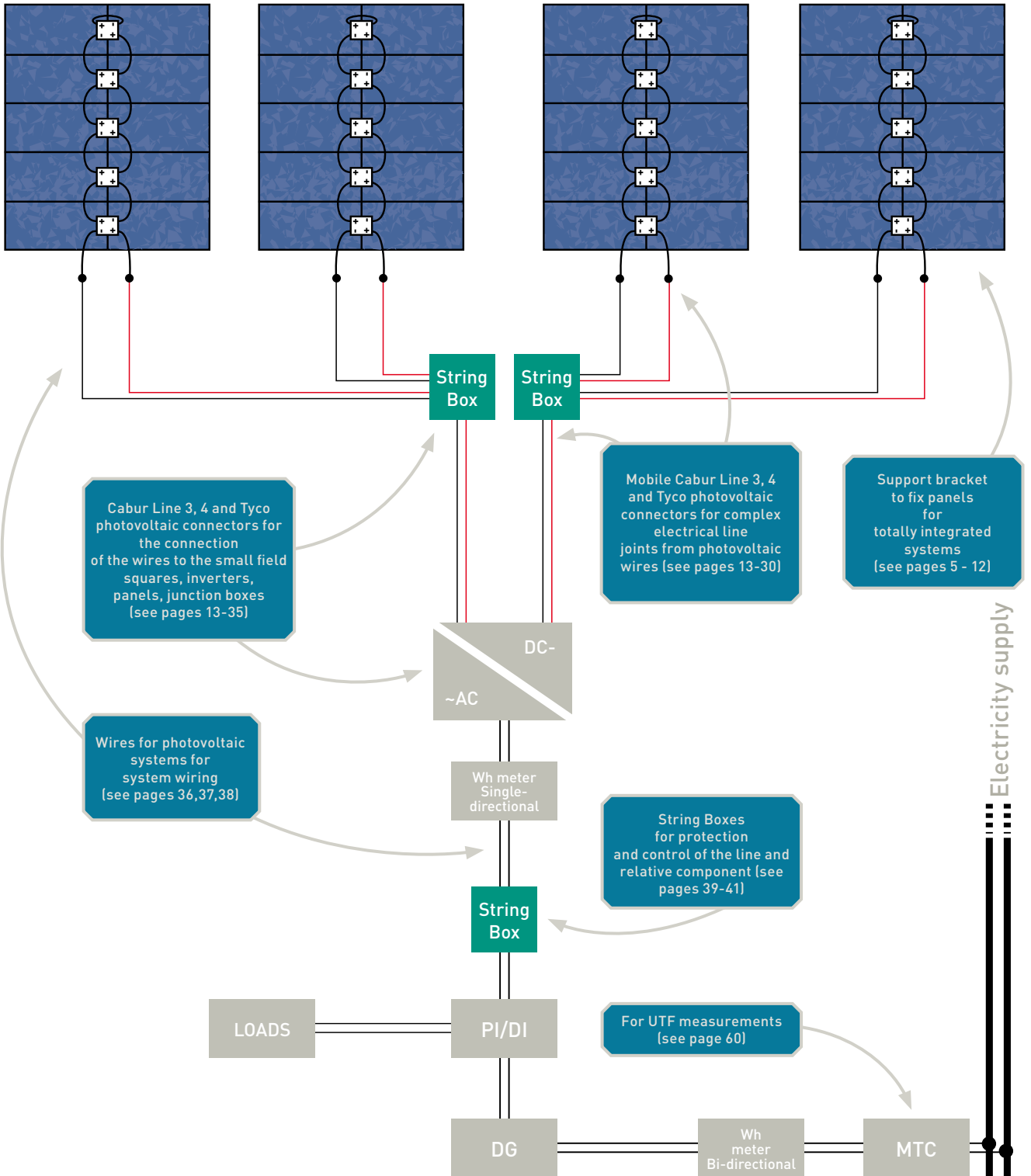

Cabur Solar Fix

Support bracket to anchor the photovoltaic panels

+ EFFICIENCY
- COSTS

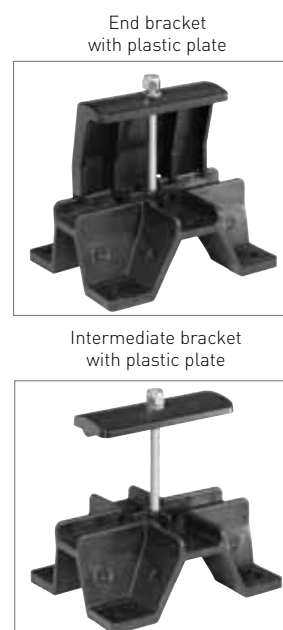
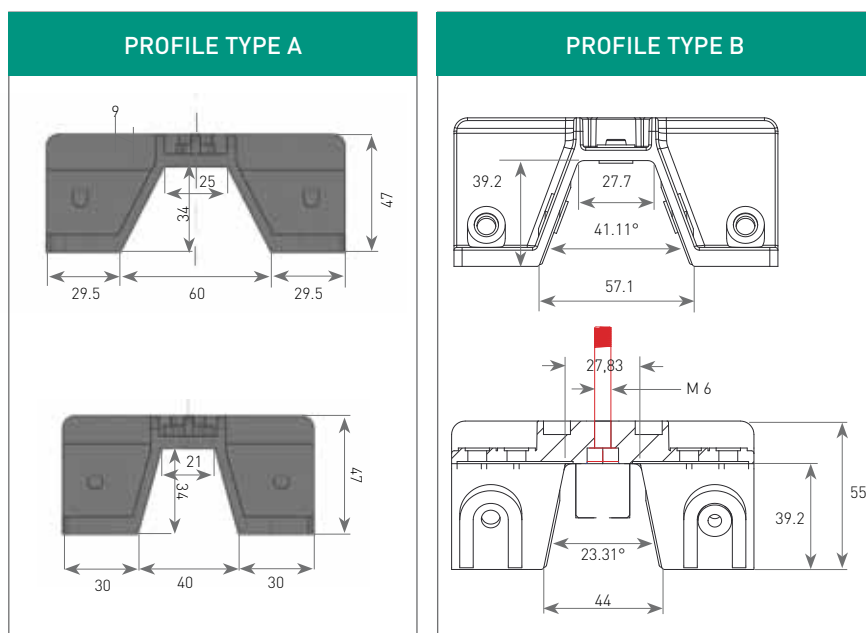

Innovative patented system for positioning and fixing photovoltaic panels equipped with metallic frames on any surface and at any angle.

The system is based on the use of brackets, complete with relative accessories (screws, washers and plates). To satisfy various installation needs, models with two different profiles are available (see figure), each of which is available with stainless steel or plastic plates.

Panel anchorage requires a certain number of intermediate brackets (to be inserted between adjacent panels) and end brackets (to be inserted at the edges of the string), depending on the number of panels to be installed.

The only difference between intermediate brackets and end brackets is the anchorage plate which, for end brackets, will obviously be L shaped since there is no adjacent panel. To calculate the number of brackets, consult the specific paragraph (see page 7).

Technical features

- Material: Duretan BKV 30H
- Estimated minimum duration: 20 years with exposure to the UVA component of sunlight
- Mechanical properties verified by the European Quality Institute in Fabriano (AN)
- Resistance to rain, wind, and UV rays verified by the European Quality Institute in Fabriano
- Maximum recommended tightening torque: 10 Nm

Patents

The Cabur Solar Fix Bracket is protected by an international patent.

Conservation of the mechanical properties

In regards to the plastic's conservation of its mechanical properties despite exposure to sunlight and therefore the UVA component, special tests were carried out by the **European Quality Institute in Fabriano (AN)**, under the inspection control of **TÜV Rheinland Italia**. The tests show that the mechanical resistance of the Cabur Solar Fix brackets remains practically constant over time, even after prolonged exposure to UVA rays.

Cabur Solar Fix

To multiply application possibilities

To choose bracket model

The Cabur Solar Fix brackets must always be bought in pairs, end and intermediate; the ratio is generally 1/2.

The choice of the best pair depends on:

- the corrugation type (A or B)

- the choice of the plate material (stainless steel or plastic material);

- the thickness of the panel.

PROFILE TYPE A

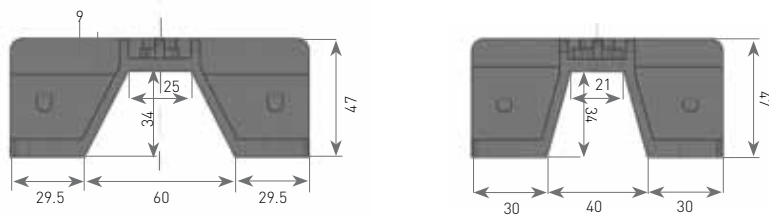

Brackets with type A profile, with stainless steel or plastic plates

Type	Intermediate	End	Intermediate	End	Intermediate	End	Intermediate	End
Panel Thickness	31 mm	31 mm	35 mm	35 mm	38 mm	38 mm	40 mm	40 mm
Stainless steel brackets code	ISFIX13	ISFIX14	ISFIX07	ISFIX02	ISFIX10	ISFIX06	ISFIX08	ISFIX05
Plastic brackets code	ISFIX13P	ISFIX14P	ISFIX07P	ISFIX02P	ISFIX10P	ISFIX06P	ISFIX08P	ISFIX05P

Type	Intermediate	End	Intermediate	End	Intermediate	End		
Panel Thickness	42 mm	42 mm	46 mm	46 mm	50 mm	50 mm		
Stainless steel brackets code	ISFIX11	ISFIX12	ISFIX09	ISFIX03	ISFIX01	ISFIX04		
Plastic brackets code	ISFIX11P	ISFIX12P	ISFIX09P	ISFIX03P	ISFIX01P	ISFIX04P		

NOTE: the ID numbers are the same as the codes

PROFILE TYPE B

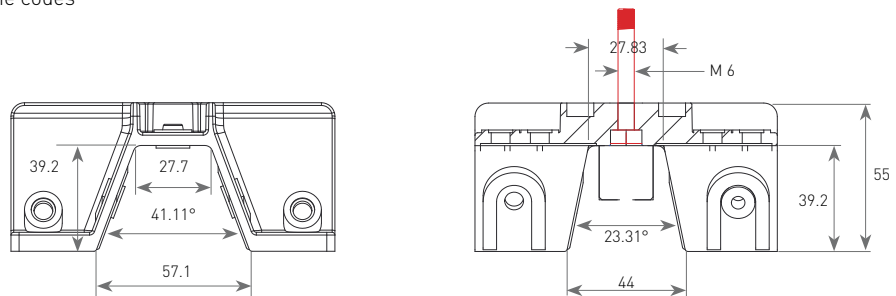

Brackets with type B profile, with stainless steel or plastic plates

Type	Intermediate	End	Intermediate	End	Intermediate	End	Intermediate	End
Panel Thickness	31 mm	31 mm	35 mm	35 mm	38 mm	38 mm	40 mm	40 mm
Stainless steel brackets code	ISFIX13B	ISFIX14B	ISFIX07B	ISFIX02B	ISFIX10B	ISFIX06B	ISFIX08B	ISFIX05B
Plastic brackets code	ISFIX13PB	ISFIX14PB	ISFIX07PB	ISFIX02PB	ISFIX10PB	ISFIX06PB	ISFIX08PB	ISFIX05PB

Type	Intermediate	End	Intermediate	End	Intermediate	End		
Panel Thickness	42 mm	42 mm	46 mm	46 mm	50 mm	50 mm		
Stainless steel brackets code	ISFIX11B	ISFIX12B	ISFIX09B	ISFIX03B	ISFIX01B	ISFIX04B		
Plastic brackets code	ISFIX11PB	ISFIX12PB	ISFIX09PB	ISFIX03PB	ISFIX01PB	ISFIX04PB		

NOTE: the ID numbers are the same as the codes

Cabur Solar Fix Accessories



Accessories and spare parts

Code	ISFIX00	ISFIX00B	ISFIXG
Description	Bracket profile A and 110x130 mm rubber sheet (the package does not contain any other accessories)	Bracket profile B and 110x130 mm rubber sheet (the package does not contain any other accessories)	Insulating rubber sheets, 110x130 mm
Quantity per package	5 pieces per package	5 pieces per package	20 pieces per package



Code	ISFIXDAF	ISFIXVLO
Description	Stainless steel anti-theft tear-off nut	Stainless steel self-piercing and self-threading screw for attachment to all Cabur Solar Fix brackets for corrugated sheet metal roofs
Quantity per package	50 pieces per package	500 pieces per package

Composition of every package

- 5 bracket pieces in BKV 30H Durethan type plastic material
- 5 stainless steel screws (height depending on module to be attached)
- 5 stainless steel self-locking nuts
- 5 stainless steel washers
- 5 rubber sheets 110x130 mm
- 5 plates (intermediate or end) in stainless steel or in BKV 30H Durethan plastic material

Calculation of the number of brackets

When calculating the quantity, take into consideration:

- the number of panels (P) in every row
- the number of rows of panels (N)
- the number of strings (Sr)

Calculation of the number of brackets (S)

- for 1 row of panels: $S = 2P + 2$
- if the string has N rows: $S = N(2P + 2)$
- if Sr is the number of strings of the system:
 $S = SrN(2P + 2)$

NOTE: the above formulas give the exact number of brackets required for each square or rectangular string with a continuous structure, i.e. with no empty spaces between them. For strings with other or irregular shapes, the formulae give a purely indicative value.

Cabur Solar Fix

Many advantages and a savings of 30%

1. Possibility of exploiting surfaces otherwise not used

Although it is true that a surface of panels that do not face in the optimum direction has a lower yield, it is also true that it will, in any case, yield a quantity of energy in addition to that produced by the other strings of the system.

The construction of a photovoltaic system involves the installation of the panels in a manner which satisfies the basic requisites such as SOUTH facing and an optimum TILT angle, as well as other factors to minimise the effect of shade and dirt which could occur.

The table below shows, for example, that a panel facing west sloping 0° (horizontal) yields almost as much as the classic south-facing panel at a 30° tilt. Thanks to its versatility, the Cabur Solar Fix bracket allows for fixing the panels at different angles, exploiting all available surfaces.

	The angle of tilt			
Horizontal	0°	30°	60°	90°
East	93%	90%	78%	55%
South-East	93%	96%	88%	66%
South	93%	100%	91%	68%
South-West	93%	96%	88%	66%
West	93%	90%	78%	55%

2. Maximum yield

The special shape of the bracket creates a hollow ventilation space, without the hindrance of secondary structures, of more than 4 cm between the photovoltaic module and the surface beneath. This means that the system is less subject to overheating, giving a greater yield.

3. Universal and versatile

Thanks to the two corrugation profiles, it is possible to cover practically every type of corrugated panel measurement; the holes in the wings at the base of the bracket also allow for use on wood or cement roofs.

The bracket can be used to anchor the photovoltaic panel strings on normal tiled roofs of civil buildings, as well as on metallic roofs typical of industrial buildings.

4. Simple and lightweight

Assembly is fast and simple: with a few steps, the bracket is ready to anchor the photovoltaic modules.

The support is light due to the material used (especially if compared to the traditional aluminium anchorage profiles). The bracket also has exceptional mechanical resistance which, together with its light weight, makes the installer's work much easier when laying the panels. It will no longer be necessary to lift up to the roof, sometimes working in extremely uncomfortable positions, large quantities of aluminium profiles, but above all it will no longer be necessary

The Great Innovation in anchorage systems

1. With maximum exploitation of the surface, positioning the panels at different slopes, following the shape of the surface on which they rest.
2. Obtain the maximum output from the system, reducing heating of the panels to the minimum.
3. Universal and versatile, suitable for almost all sandwich panels on the market, on corrugated metal roofs, tiled, or wooden or cement roofs.
4. Allows simple and fast installation, with lightweight, easy to handle components.

5. For aesthetically and architecturally elegant and modern solutions.
6. Perfect for attaching panels to corrugated metal roofs, when replacing Ethernit roofs.
7. Made of eco-friendly materials, chosen to ensure maximum duration of system components.
8. Costing about 30% less, for the same power installed, than traditional systems using aluminium profiles.

Cabur Solar Fix

to cut and shape the metallic frames to adapt them to both the panels and the shape of the roofing. In addition, with the same surface area and using the same type of photovoltaic panels, with Cabur Solar Fix brackets more panels can be installed, placed much closer together and with only minimal space left between them.

5. Possible to obtain aesthetically and architecturally elegant and modern solutions

The system based on Cabur Solar Fix brackets allows architects to develop aesthetically elegant solutions and to give them a personal character, altering the geometry of the buildings according to photovoltaic technology, in an architectural combination of harmoniously pleasant forms and at the same time with a modern appearance, which can make a mark over time on the architectural style.

6. Possibility to exchange old and dangerous Ethernit roofs with an elegant replacement

Old roofs in Ethernit are normally replaced by corrugated metallic roofs. Cement slabs containing asbestos on industrial roofs are generally replaced by steel-insulation-steel sandwich panels.

The Cabur Solar Fix device is ideal for anchoring photovoltaic modules to this type of roof, thanks to its design which adapts perfectly to the sizes of the standard corrugations.

7. Quality of the material

The bracket is made of Duretan BKV 30H by Bayer/Lanxess, already used in the automotive sectors and for other photovoltaic applications. Especially on metallic roofs, this material insulates the roof from the photovoltaic module, avoiding the formation of galvanic and creeping currents. This means that there will be no anodic oxidation of the metals in contact with each other, nor rust problems in areas near the shore where the atmosphere is warm, damp and salty.

Furthermore, the material is not subject to rot or to freezing, and it is resistant at both high and low temperatures.

Less energy is needed for its production than for metal brackets, which means lower CO² emissions into the atmosphere. The brackets are also made with 20% recycled material.

8. Cost

Since about 10 brackets are needed for every kW of photovoltaic power installed (including intermediate and end brackets), compared to traditional anchorage systems with aluminium profiles and with the same amount of photovoltaic power installed on the roof, **using Cabur Solar Fix reduces costs by about 30%.**

Cabur Solar Fix

Recommendations for correct use

Fixing of photovoltaic panels with metallic border

The bracket allows for anchorage on:

- sandwich panels (the typical roofs of industrial sheds);
- smooth sloping roofs (the typical roofs of residential dwellings with rounded tiles) and on cement mix surfaces or wooden planks;
- corrugated steel

Approximate indications are given below for the most common cases.

EXAMPLE OF INSTALLATION ON METALLIC SANDWICH PANELS WITH NARROW CORRUGATION

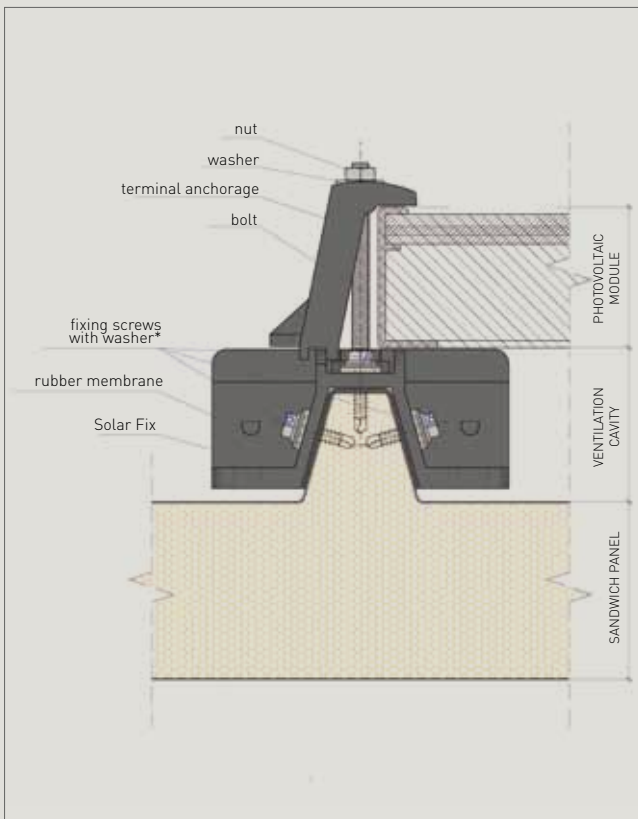

A - anchorage with screws on steel sandwich panels can be carried out with the upper vertical holes (A) and/or the prints on the sloping walls of the bracket (B)

Bracket on narrow corrugation

Installation on corrugated metal

Most sandwich panels have two different corrugation sizes: narrow and wide. The bracket can be positioned according to the profile of the type of panel (see drawing below left).

Installation of series on metallic roofs in sandwich panels

The following sequence of images shows the steps for the creation of the photovoltaic system on metallic roofs of industrial sheds.



The brackets are anchored to the corrugations of the panels with perforating and self-threading screws at reciprocal distances depending on the size of the single photovoltaic panel. (Photovoltaic system constructed by General Building SpA, Polverigi, Ancona, Italy).



The presence of the corrugations allows for fast and simple alignment of the brackets. (Photovoltaic system constructed by General Building SpA, Polverigi, Ancona, Italy).

Cabur Solar Fix



The various panels of the various photovoltaic strings are then positioned. (Photovoltaic system constructed by General Building SpA, Polverigi, Ancona, Italy).



The string is "closed" with the end brackets on the perimeter. The intermediate wiring of each string, as the connection of the same to the rest of the system, is carried out and assured with CABUR mobile photovoltaic connectors. (Photovoltaic system constructed by Energy Resources srl, Ancona, Italy).



The system is finished and ready to be connected to the inverter. (Photovoltaic system constructed by Energy Resources srl, Ancona, Italy).



The system is functioning. (Photovoltaic system constructed by Energy Resources srl, Ancona, Italy).



Example of a perimeter cover to achieve complete architectural integration. (Photovoltaic system constructed by General Building SpA, Polverigi, Ancona, Italy).

Cabur Solar Fix

Recommendations for correct use

Installation on rounded tiles

1. Decide on which slope of the roof the modules will be placed.
2. Remove the tiles or pantiles to uncover the underlying waterproofing layer.
3. Position and fix the first series of brackets, using the panels themselves as a geometric reference.
4. Position the second series, marking the points where holes need to be drilled for the final fixing of the second row of brackets. Proceed in this way until all the supporting brackets have been fixed.

Please note:

- To avoid water seepage, every hole must be made waterproof, covering the head of each screw with an insulating material such as weather proof tar sealants, chemical or liquid resins, special weatherproof silicon, polyurethane sleeves, or sheet-metal silicon, which adheres to both the metallic head of the screw and the plastic base of the bracket preventing any penetration of water.
- To obtain architectonic integration, the photovoltaic panels must be positioned near the pantiles. It is best to cement the last row of tiles.

On completion, the series of panels covers the slope of the roof harmoniously and the photovoltaic system is linear, tidy, and aesthetically clean, which is certainly not the case with the positioning of the classic aluminium spars on the tiles.

EXAMPLE OF INSTALLATION ON SMOOTH SLOPING ROOFS WITH A STRUCTURE IN CEMENT MIX

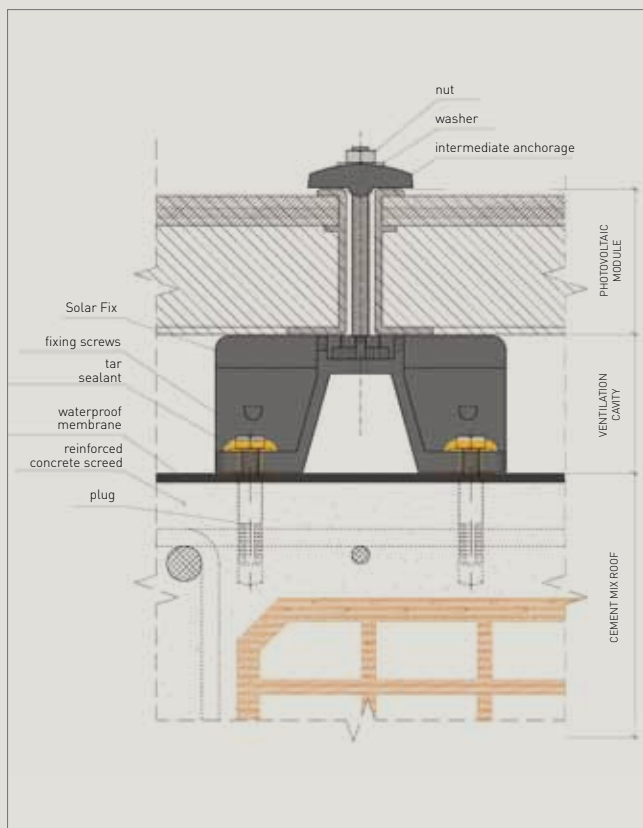

Example of installation on smooth sloping roofs with a structure in cement mix

EXAMPLE OF INSTALLATION ON SMOOTH SLOPING ROOFS MADE OF WOODEN PLANKS

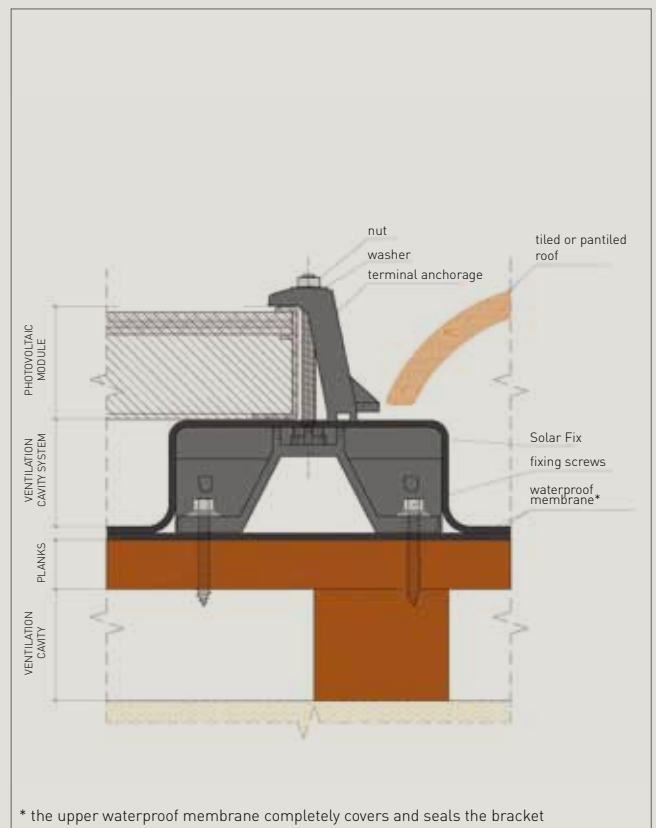

Example of installation on smooth sloping roofs made of wooden planks

Cabur Solar connectors

For connection with the most common inverters and junction boxes

With Cabur Solar connectors, connections are simple and effective for the most common inverters/junction boxes.

There are essentially two categories or groups:

- Line 3, with \varnothing 3mm metal contacts;
- Line 4, with \varnothing 4mm metal contacts.

These lines can in turn be divided into:

- mobile connectors, male and female;
- panel connectors, male and female;
- Y connectors for forked lines;
- caps and accessories.

All Cabur Solar connectors feature:

- maximum voltage: 1000 DC;
- contact resistance: $< 5 \text{ m}\Omega$;
- contact material: tin-plated copper;
- insulation: PPO;
- degree of protection; IP67 (IEC 60529);
- temperature range: $-40^\circ\text{C} +85^\circ\text{C}$;
- flammability class: UL94-V0.

To guarantee correct fixing according to standards, Cabur recommends the use of the professional UMCT crimper, together with the matrix IS3153 for Line 3 connectors and IS3154 for Line 4 connectors, or the IS3161 crimper (see page 31).

To ensure the guarantee's effectiveness, the use of Cabur Solar tools, in conformance with the standards and instructions found in Cabur official documentation, is an essential requirement.



The line includes mobile and panel connectors certified TÜV.



Fast, simple, and effective: connection in just three steps

1. Insert the stripped wire into the crimp contact -CRIMP-
2. Insert the wire complete with contact into the connector and push hard until you hear the typical CLICK which indicates that the plastic and metal parts are hooked together. Do not make any joints without checking that the plastic and metal parts are hooked together.
3. Screw on the wire gland washer manually until it is firmly home to guarantee IP67.



Cabur Solar connectors

Composition and materials

Line 3 and 4 mobile male-female connectors

These are composed of 4 basic parts (figs. 1 and 4):



Fig. 1 - Exploded view of the panel connector body. (The product is provided assembled)

1. A metallic contact known as a PIN (fig. 4) made of tinned copper and formed using a moulding technique. It has two wings necessary to anchor it to the electric wire. This is done by crimping or mechanically, using matrix **IS3153-IS3154** in the relevant pliers **UMCT3149**, which, by bending the wings on the metallic core of the photovoltaic wire (fig. 2, 3), ensures correct and safe anchoring in accordance with **CEI EN 60352-2**. Perfect insulation of the metallic contact can be further guaranteed by placing **IS51400** and **IS52400** caps

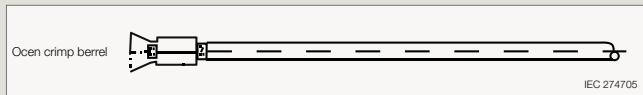

Fig. 2 - Wire crimped onto PIN

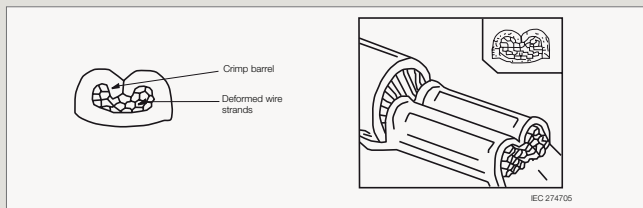

Fig. 3 - Wire crimped onto PIN

on the connector. The PIN can be male or female and have a diameter of 3 or 4 mm. The male PINS with 3mm diameter have a cap which insulates the head to ensure insulation of **IP20**. The male 4mm PIN, which remains deeply set into the insulating cavity of the relative connector, does not need an insulating cap (fig. 4).

2. A rubber washer for waterproofing the internal part of the connector, preventing the penetration of external agents such as humidity, dust, and oils, by squeezing the insulating sleeve of the electric wire.



Fig. 4 - series 3 (right hand pair) and series 4 (left hand pair) PINS

3. A rigid PPO plastic washer with a conical cavity that, after being screwed onto the main body of the connector, forces the reeds together, compressing the rubber sleeve onto the wire insulation and hence acting to help ensure **IP67** protection established on the basis of Technical Standard **CEI EN 60529**.

4. A main body made of PPO plastic which holds the metallic PIN crimped onto the wire. The male connector holds the male metallic contract (PIN) while the female connector holds the female metallic contract (PIN). The male PIN penetrates the female PIN (as for every other electrical-mechanical connecting device), while the opposite is true for the plastic connector (the insulating sleeve): the female penetrates the male. For this reason, the outer surface of the female connector of Line 3 has two red rubber rings which act as insulating washers against the penetration of external atmospheric agents. Similarly, the female connector of Line 4 has a red rubber ring for the same purpose.

The Line 3 connector, being shorter, is more exposed to atmospheric agents and for this reason is provided with a double ring, unlike Line 4 which has only one, as it can penetrate deeper into the relative male and is hence better protected from outside agents.

The male and female connectors hook together mechanically by means of two pointed anchored elastic wings on the female connectors which must be inserted in the special slots on the insulating body of the male connectors.

Everything is rigidly and firmly connected and accidental unhooking of the two connectors, or the chance interruption of the line from the photovoltaic field, is impossible. Disconnection is possible only by pressing the male wings with your fingers and simultaneously pulling the female out of the male manually, without the aid of any tool.

Cabur Solar connectors

Male-female panel connectors of Lines 3 and 4

These are composed of 3 parts (fig. 5):



Fig. 5 – Exploded view of the connector body. The product is provided assembled.

1. A **metallic contact** that is the same as the PIN on the mobile version.

2. A **main body made of PPO plastic** holding the metallic PIN crimped onto the wire which has a red rubber ring located between the surface of the connector and the wall of the box or sheet metal where the connector is installed. This ring acts to create a compressed washer between the connector and the panel able to protect both from being penetrated by atmospheric agents and hence guaranteeing **IP67** protection as in CEI EN 60529. Compression of the insulating ring occurs through tightening the relevant hexagonal nut to fix the panel. The mobile male connectors are hooked to the female panel connectors (or vice versa) as previously described for the connection between mobile connectors. Everything is rigidly connected and there is no possibility of accidentally unhooking the two connectors and accidentally breaking the line coming from the photovoltaic field. Disconnection is only possible by pressing the two male wings and simultaneously pulling the female body out of the male body.

3. A **hexagonal nut** used to lock the connector against the steel surface of the panel. These connectors are in plastic and therefore the nut must not be tightened with too much force otherwise the thread would immediately be flattened.

For panel connectors, always attach the DO NOT DISCONNECT UNDER LOAD sticker near the connector on the surface of the box where it will be fitted.

Rubber-plastic mobile connectors for Line 3

These are appropriate for connections to both mobile and panel MC3 connectors. This means they can be used for connections for both photovoltaic panels (if provided with the appropriate retention hook), and for Inverter panels (without retention hook). Both connectors, male and female, consist of:

- a metallic tin-plated copper PIN
- a rubber-plastic insulating body
- a washer to obtain IP67
- a closing washer

As the main body of the connector is made of two materials, it ensures speed and simplicity during assembly thanks to the plastic side as well as universal joints thanks to the rubber side. Using these connectors it is possible to connect to any type of photovoltaic device (panel, inverter, string box, etc.) and provide IP67 joints, with the use of Cabur Solar line tools. The joint is created by performing the same operations indicated for the other Line 3 connectors. The rubber side has a series of grooves which when combined with the similar grooves on the MC3 connectors, ensure mechanical anchorage. The presence of the retention hook which is lowered onto the mobile MC3 connector guarantees an even stronger mechanical coupling. The choice of hook will depend on the dimensions of the MC3 connector to be used - shorter for 40 mm mobile MC3 models and longer for 50 mm models.



Fig. 6 - Exploded view of the rubber connector.

Cabur Solar connectors

Electrothermal tests

The electrothermal tests carried out for various joints at the KEMA labs in Holland demonstrate the efficiency of Cabur Solar connectors.

The 5 images below show the results obtained from a joint created by the male-female coupling of IS14240 and IS24241 connectors from Line 4.

The results were excellent. The joint, subjected to amperage increasing from 10, to 20, 30, 40, and 50A did not show any signs of overheating which could make usage dangerous. The thermographs show a generally linear thermal gradient,

equal to 1°C/A such that, even for amperages which exceed the maximum allowed 30 A, the joint remains "cold," demonstrating low thermal generation due to the Joule effect. Consequently, there is a low contact resistance and hence low dissipation of electrical power, which has the final consequence of increasing the overall performance of the photovoltaic system. Similar results were obtained for all the other joints, both for Line 3 and Line 4 connectors.

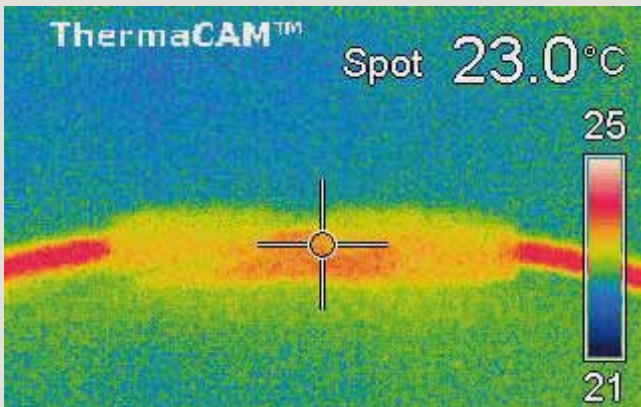

Fig. 1 - Thermograph at 10 A

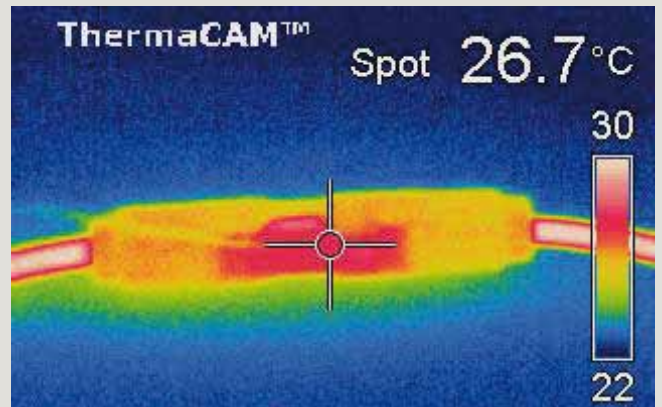

Fig. 2 - Thermograph at 20 A

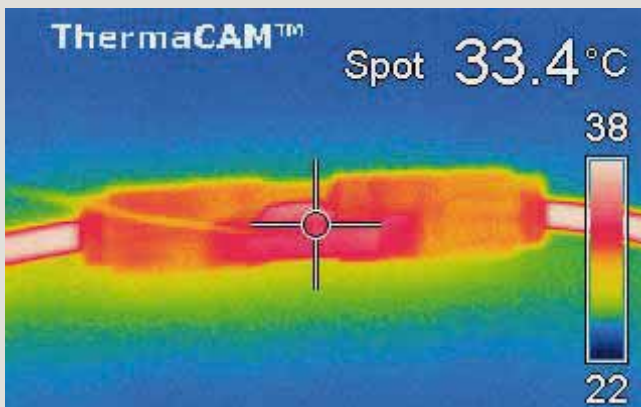

Fig. 3 - Thermograph at 30 A

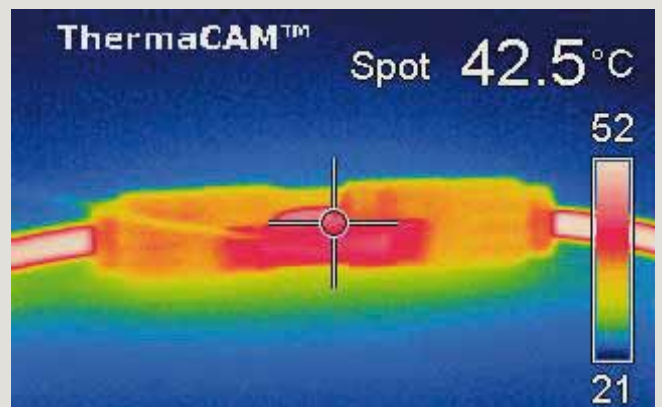

Fig. 4 - Thermograph at 40 A

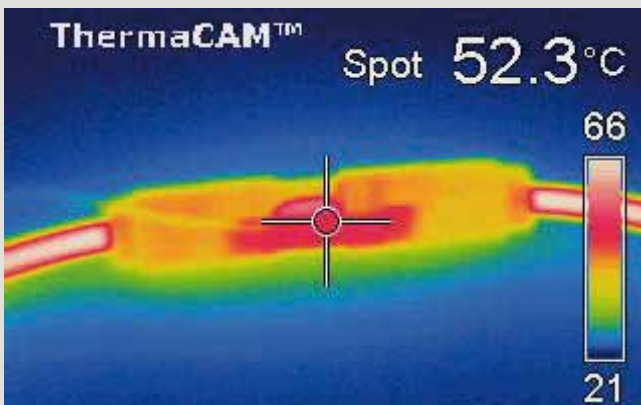

Fig. 5 - Thermograph at 50 A

WARNING!
The maximum usable current for all Cabur Solar Line connectors is 25 A. The thermographs shown here demonstrate extreme situations which illustrate the quality of the product. They are not intended to suggest or guarantee project conditions.

Cabur Solar connectors

Line 3



Normal packaging: the code refers to packets composed of plastic and metal parts (outer shell + PIN)

Use	On StringBox and/or inverter		On StringBox and/or inverter	
Code	IS13110	IS23111	IS13112	IS23113
ID number	KX03PM1525	KX03PF1525	KX03PM4060	KX03PF4060
Application	Panel	Panel	Panel	Panel
Connector type	Male	Female	Male	Female
PIN diameter	3 mm	3 mm	3 mm	3 mm
Section of crimpable wires	1.5 mm ² 2.5 mm ²	1.5 mm ² 2.5 mm ²	4 mm ² 6 mm ²	4 mm ² 6 mm ²
Pliers	UMCT3149	UMCT3149	UMCT3149	UMCT3149
Matrix	IS3153	IS3153	IS3153	IS3153
Features of metallic PIN	Tin-plated copper	Tin-plated copper	Tin-plated copper	Tin-plated copper
Contact resistance:	Rc < 5 mΩ	Rc < 5 mΩ	Rc < 5 mΩ	Rc < 5 mΩ
PIN type	Moulded	Moulded	Moulded	Moulded
Shell features	Plastic (PPO)	Plastic (PPO)	Plastic (PPO)	Plastic (PPO)
Maximum applicable voltage	1000 DC	1000 DC	1000 DC	1000 DC
Maximum applicable current	25 A	25 A	25 A	25 A
Admitted working temperature range	- 40° < T < +85°	- 40° < T < +85°	- 40° < T < +85°	- 40° < T < +85°
Degree of protection	IP67	IP67	IP67	IP67
Flammability class	UL94-V0	UL94-V0	UL94-V0	UL94-V0
Certifications obtained	-	-	TÜV	TÜV
Quantity per package	100	100	100	100
Packaging	One box contains 10 sachets. Every sachet contains 10 plastic shells and 10 metallic contacts (PINS)			

Plastic shell only

Code	ISPAN3M	ISPAN3F	ISPAN3M	ISPAN3F
Packaging	One packet contains 100 plastic shells			

Metallic contact (PIN) only

Code	ISPIN31525M	ISPIN31525F	ISPIN34060M	ISPIN34060F
Packaging	One packet contains 10 sachets and each sachet contains 10 PINS for a total of 100 PINS			

Metallic contact on coil only

Code	IS0701206	IS0701208	IS0701207	IS0701209
Packaging	Tape with 2000 PINs for wires with a 1.5 mm ² or 2.5 mm ² section		Tape with 2000 PINs for wires with a 4 mm ² or 6 mm ² section	

Pre-wired connectors available on demand For information contact the Cabur sales network

Pre-wired connectors



For joints with MC connectors, see page 25. (except pre-wired connectors)

Cabur Solar connectors

Line 3



Normal packaging: the code refers to packets composed of plastic and metal parts (outer shell + PIN)

Use	Extensions (wire/wire connections)		Extensions (wire/wire connections)	
Code	IS13240	IS23241	IS13242	IS23243
ID number	KX03VM1525	KX03VF1525	KX03VM4060	KX03VF4060
Application	Mobile connector	Mobile connector	Mobile connector	Mobile connector
Connector type	Male	Female	Male	Female
PIN diameter	3 mm	3 mm	3 mm	3 mm
Section of crimpable wires	1.5 mm ² 2.5 mm ²	1.5 mm ² 2.5 mm ²	4 mm ² 6 mm ²	4 mm ² 6 mm ²
Pliers	UMCT3149	UMCT3149	UMCT3149	UMCT3149
Matrix	IS3153	IS3153	IS3153	IS3153
Features of metallic PIN	Tin-plated copper	Tin-plated copper	Tin-plated copper	Tin-plated copper
Contact resistance	Rc < 5 mΩ	Rc < 5 mΩ	Rc < 5 mΩ	Rc < 5 mΩ
PIN type	Moulded	Moulded	Moulded	Moulded
Shell features	Plastic (PPO)	Plastic (PPO)	Plastic (PPO)	Plastic (PPO)
Maximum applicable voltage	1000 DC	1000 DC	1000 DC	1000 DC
Maximum applicable current	25 A	25 A	25 A	25 A
Admitted working temperature range	- 40° < T < +85°	- 40° < T < +85°	- 40° < T < +85°	- 40° < T < +85°
Degree of protection	IP67	IP67	IP67	IP67
Flammability class	UL94-V0	UL94-V0	UL94-V0	UL94-V0
Certifications obtained	-	-	TÜV	TÜV
Quantity per package	100	100	100	100
Packaging	One box contains 10 sachets. Every sachet contains 10 plastic shells and 10 metallic contacts (PINS)			

Plastic shell only

Code	ISVOL3M	ISVOL3F	ISVOL3M	ISVOL3F
Packaging	One packet contains 100 plastic shells			

Metallic contact (PIN) only

Code	ISPIN31525M	ISPIN31525F	ISPIN34060M	ISPIN34060F
Packaging	One packet contains 10 sachets and each sachet contains 10 PINS for a total of 100 PINS			

Metallic contact on coil only

Code	IS0701206	IS0701208	IS0701207	IS0701209
Packaging	Tape with 2000 PINs for wires with a 1.5 mm ² or 2.5 mm ² section		Tape with 2000 PINs for wires with a 4 mm ² or 6 mm ² section	

Pre-wired connectors available on demand For information contact the Cabur sales network

Pre-wired connectors





Normal packaging: the code refers to packets composed of plastic and metal parts (outer shell + PIN)

Use	Only for connections with photovoltaic panels with short-type MC3 (40 mm)		Only for connections with photovoltaic panels with long-type MC3 (50 mm)	
Code	IS15240	IS25241	IS15242	IS25243
ID number	KX03VM2540GC	KX03VF2540GC	KX03VM4060GL	KX03VF4060GL
Application	Mobile connector with short retention hook		Mobile connector with long retention hook	
Connector type	Male	Female	Male	Female
PIN diameter	3 mm	3 mm	3 mm	3 mm
Section of crimpable wires	2.5 mm ² 4 mm ²	2.5 mm ² 4 mm ²	4 mm ² 6 mm ²	4 mm ² 6 mm ²
Pliers	UMCT3149	UMCT3149	UMCT3149	UMCT3149
Matrix	IS3153	IS3153	IS3153	IS3153
Features of metallic PIN	Tin-plated copper	Tin-plated copper	Tin-plated copper	Tin-plated copper
Contact resistance	Rc < 5 mΩ	Rc < 5 mΩ	Rc < 5 mΩ	Rc < 5 mΩ
PIN type	Moulded	Moulded	Moulded	Moulded
Shell features	Plastic (PPO)	Plastic (PPO)	Plastic (PPO)	Plastic (PPO)
Maximum applicable voltage	1000 DC	1000 DC	1000 DC	1000 DC
Maximum applicable current	25 A	25 A	25 A	25 A
Admitted working temperature range	- 40° < T < +85°	- 40° < T < +85°	- 40° < T < +85°	- 40° < T < +85°
Degree of protection	IP67	IP67	IP67	IP67
Flammability class	UL94-V0	UL94-V0	UL94-V0	UL94-V0
Certifications obtained	-	-	-	-
Quantity per package	100	100	100	100
Packaging	One box contains 10 sachets. Every sachet contains 10 plastic shells and 10 metallic contacts (PINS)			

Plastic shell only

Code	ISVOL3GM	ISVOL3GF	ISVOL3GML	ISVOL3GFL
Packaging	One packet contains 100 plastic shells			

Metallic contact (PIN) only

Code	ISPIN34060M	ISPIN34060F	ISPIN34060M	ISPIN34060F
Packaging	One packet contains 10 sachets and each sachet contains 10 PINS for a total of 100 PINS			

Metallic contact on coil only

Code	-	-	IS0701207	IS0701209
Packaging	Tape with 2000 PINS for wires with a 4 mm ² or 6 mm ² section			

Pre-wired connectors available on demand For information contact the Cabur sales network

Hooks

IS15000 short hook (1)

IS15001 long hook (2)

(1)



(2)



For joints with MC connectors, see page 25. (except pre-wired connectors)

Cabur Solar connectors

Line 3



Normal packaging: the code refers to packets composed of plastic and metal parts (outer shell + PIN)

Use	For connections with photovoltaic panels with short-type MC3 (40 mm)		For connections with photovoltaic panels with short-type MC3 (40 mm) or to connect to inverters that use MC3 (remove the hook from the Cabur connector when it is connected to the inverter)	
Code	IS15340	IS25341	IS15341	IS25342
ID number	KX03VM1525GC	KX03VF1525GC	KX03VM4060GC	KX03VF4060GC
Application	Mobile connector with short retention hook	Mobile connector with short retention hook	Mobile connector with short retention hook	Mobile connector with short retention hook
Connector type	Male	Female	Male	Female
PIN diameter	3 mm	3 mm	3 mm	3 mm
Section of crimpable wires	1.5 mm ² 2.5 mm ²	1.5 mm ² 2.5 mm ²	4 mm ² 6 mm ²	4 mm ² 6 mm ²
Pliers	UMCT3149	UMCT3149	UMCT3149	UMCT3149
Matrix	IS3153	IS3153	IS3153	IS3153
Features of metallic PIN	Tin-plated copper	Tin-plated copper	Tin-plated copper	Tin-plated copper
Contact resistance	Rc < 5 mΩ	Rc < 5 mΩ	Rc < 5 mΩ	Rc < 5 mΩ
PIN type	Moulded	Moulded	Moulded	Moulded
Shell features	Rubber-Plastic (PPO)	Rubber-Plastic (PPO)	Rubber-Plastic (PPO)	Rubber-Plastic (PPO)
Maximum applicable voltage	1000 DC	1000 DC	1000 DC	1000 DC
Maximum applicable current	25 A	25 A	25 A	25 A
Admitted working temperature range	- 40° < T < +85°	- 40° < T < +85°	- 40° < T < +85°	- 40° < T < +85°
Degree of protection	IP67	IP67	IP67	IP67
Flammability class	UL94-V0	UL94-V0	UL94-V0	UL94-V0
Certifications obtained	-	-	-	-
Quantity per package	100	100	100	100
Packaging	One box contains 10 sachets. Every sachet contains 10 plastic shells and 10 metallic contacts (PINS)			

Plastic shell only

Code	ISVOL3MGPGC	ISVOL3FGPGC	ISVOL3MGPGC	ISVOL3FGPGC
Packaging	One packet contains 100 plastic shells			

Metallic contact only

Code	ISPIN31525M	ISPIN31525F	ISPIN34060M	ISPIN34060F
Packaging	One packet contains 10 sachets and each sachet contains 10 PINS for a total of 100 PINS			

Metallic contact on coil only

Code	IS0701206	IS0701208	IS0701207	IS0701209
Packaging	Tape with 2000 PINS for wires with a 1.5 mm ² or 2.5 mm ² section		Tape with 2000 PINS for wires with a 4 mm ² or 6 mm ² section	

Pre-wired connectors available on demand For information contact the Cabur sales network

Hooks
IS15000 short hook (1)
IS15001 long hook (2)

(1)



(2)





Normal packaging: the code refers to packets composed of plastic and metal parts (outer shell + PIN)

Use	For connections with photovoltaic panels with long-type MC3 [50 mm] or to connect to inverters that use MC3 (remove the hook from the Cabur connector when it is connected to the inverter)	
Code	IS15342	IS25343
ID number	KX03VM4060GL	KX03VF4060GL
Application	Mobile connector with long retention hook	Mobile connector with long retention hook
Connector type	Male	Female
PIN diameter	3 mm	3 mm
Section of crimpable wires	4 mm ² 6 mm ²	4 mm ² 6 mm ²
Pliers	UMCT3149	UMCT3149
Matrix	IS3153	IS3153
Features of metallic PIN	Tin-plated copper	Tin-plated copper
Contact resistance	Rc < 5 mΩ	Rc < 5 mΩ
PIN type	Moulded	Moulded
Shell features	Rubber-Plastic (PPO)	Rubber-Plastic (PPO)
Maximum applicable voltage	1000 DC	1000 DC
Maximum applicable current	25 A	25 A
Admitted working temperature range	- 40° < T < +85°	- 40° < T < +85°
Degree of protection	IP67	IP67
Flammability class	UL94-V0	UL94-V0
Certifications obtained	-	-
Quantity per package	100	100
Packaging	One box contains 10 sachets. Every sachet contains 10 plastic shells and 10 metallic contacts (PINS)	

Plastic shell only

Code	ISVOL3MGPGL	ISVOL3FGPGL
Packaging	One packet contains 100 plastic shells	

Metallic contact only

Code	ISPIN34060M	ISPIN34060F
Packaging	One packet contains 10 sachets and each sachet contains 10 PINS for a total of 100 PINS	

Metallic contact on coil only

Code	IS0701207	IS0701209
Packaging	Tape with 2000 PINS for wires with a 4 mm ² or 6 mm ² section	

Pre-wired connectors available on demand For information contact the Cabur sales network

Hooks

IS15000 short hook (1)

IS15001 long hook (2)

(1)



(2)



Cabur Solar Y connectors

Line 3



Normal packaging: the code refers to packets composed of plastic and metal parts (outer shell + PIN)

Use	To create parallels between strings of panels with short-type MC3 connectors (40 mm)		To create parallels between strings of panels with long-type MC3 connectors (50 mm)	
Code	IS41310S	IS42320S	IS41310L	IS42320L
ID number	KX03MFFGS	KX03FMMGS	KX03MFFGL	KX03FMMGL
Application	Mobile connector	Mobile connector	Mobile connector	Mobile connector
Connector type	Male/Female-Female	Female/Male-Male	Male/Female-Female	Female/Male-Male
PIN diameter	3 mm	3 mm	3 mm	3 mm
Section of crimpable wires	All	All	All	All
Pliers	NO	NO	NO	NO
Matrix	NO	NO	NO	NO
Features of metallic PIN	Tin-plated copper	Tin-plated copper	Tin-plated copper	Tin-plated copper
Contact resistance	Rc < 5 mΩ	Rc < 5 mΩ	Rc < 5 mΩ	Rc < 5 mΩ
PIN type	Moulded	Moulded	Moulded	Moulded
Shell features	Plastic (PPO)	Plastic (PPO)	Plastic (PPO)	Plastic (PPO)
Maximum applicable voltage	1000 DC	1000 DC	1000 DC	1000 DC
Maximum applicable current	25 A	25 A	25 A	25 A
Admitted working temperature range	- 40° < T < +85°	- 40° < T < +85°	- 40° < T < +85°	- 40° < T < +85°
Degree of protection	IP67	IP67	IP67	IP67
Flammability class	UL94-V0	UL94-V0	UL94-V0	UL94-V0
Certifications obtained	-	-	-	-
Quantity per package	30	30	30	30
Packaging	One box contains 6 sachets. Every sachet contains 5 Y joints		One box contains 6 sachets. Every sachet contains 5 Y joints	

Plastic shell only

Code	-	-	-	-
Packaging				

Metallic contact (PIN) only

Code	-	-	-	-
Packaging				

Metallic contact on coil only

Code	-	-	-	-
Packaging				

Pre-wired connectors available on demand For information contact the Cabur sales network

Hooks

IS15000 short hook (1)

IS15001 long hook (2)

(1)



(2)



For joints with MC connectors, see page 25. (except pre-wired connectors)

Cabur Solar connectors

Line 4



Normal packaging: the code refers to packets composed of plastic and metal parts (outer shell + PIN)

On QDC and/or inverter		Extensions (wire/wire connections) and for connection to photovoltaic and inverter panels with MC4		Y connectors	
IS14110	IS24111	IS14240	IS24241	IS41410	IS42420
KX04PM4060	KX04PF4060	KX04VM4060	KX04VF4060	KX04MFF	KX04FMM
Panel	Panel	Mobile connector	Mobile connector	Mobile connector	Mobile connector
Male	Female	Male	Female	Male/Female-Female	Female/Male-Male
4 mm	4 mm	4 mm	4 mm	4 mm	4 mm
4 mm ² 6 mm ²	4 mm ² 6 mm ²	4 mm ² 6 mm ²	4 mm ² 6 mm ²	All	All
UMCT3149	UMCT3149	UMCT3149	UMCT3149	NO	NO
IS3154	IS3154	IS3154	IS3154	NO	NO
Tin-plated copper	Tin-plated copper	Tin-plated copper	Tin-plated copper	Tin-plated copper	Tin-plated copper
Rc < 5 mΩ	Rc < 5 mΩ	Rc < 5 mΩ	Rc < 5 mΩ	Rc < 5 mΩ	Rc < 5 mΩ
Moulded	Moulded	Moulded	Moulded	Moulded	Moulded
Plastic (PPO)	Plastic (PPO)	Plastic (PPO)	Plastic (PPO)	Plastic (PPO)	Plastic (PPO)
1000 DC	1000 DC	1000 DC	1000 DC	1000 DC	1000 DC
25 A	25 A	25 A	25 A	35 A	35 A
- 40° < T < +85°	- 40° < T < +85°	- 40° < T < +85°	- 40° < T < +85°	- 40° < T < +90°	- 40° < T < +90°
IP67	IP67	IP67	IP67	IP67	IP67
UL94-V0	UL94-V0	UL94-V0	UL94-V0	UL94-V0	UL94-V0
TÜV	TÜV	TÜV	TÜV	-	-
100	100	100	100	30	30

One packet contains 10 sachets. Every sachet contains 10 plastic shells and 10 metallic contacts (PINS)

One packet contains 10 sachets. Every sachet contains 10 plastic shells and 10 metallic contacts (PINS)

One box contains 6 sachets. Every sachet contains 5 Y joints.

Plastic shell only

ISPAN4M	ISPAN4F	ISVOL4M	ISVOL4F	-	-
One packet contains 100 plastic shells		One packet contains 100 plastic shells			

Metallic contact (PIN) only

ISPIN44060M	ISPIN44060F	ISPIN44060M	ISPIN44060F	-	-
One packet contains 10 sachets and each sachet contains 10 PINS for a total of 100 PINS		One packet contains 10 sachets and each sachet contains 10 PINS for a total of 100 PINS			

Metallic contact on coil only

IS0601207	IS0601209	IS0601207	IS0601209	-	-
Tape with 2000 PINS on spool.		Tape with 2000 PINS on spool			

Pre-wired connectors available on demand For information contact the Cabur sales network



For joints with MC connectors, see page 25. (except pre-wired connectors)

Cabur Solar connectors

Accessories



Use	Ring to block manual unhooking of Cabur Line 3 and 4 photovoltaic connectors	Unhooking key to unhook photovoltaic connectors
Code	IS15BLOCK	IS15SBLOCK
ID number	IS15BLOCK	IS15SBLOCK
Application	Plastic ring inserted manually at the time of connection	This accessory makes it possible to unhook connectors after connection using accessory IS15BLOCK. It's easy to use and means only authorized personnel with the appropriate tools can perform the unhooking procedure
Connector type	All Cabur Solar Line 3 and 4 connectors	All Cabur Solar Line 3 and 4 connectors
Material	PP0	Aluminium
Quantity per package	50	2
Packaging	Every sachet contains 50 blocking rings	Every sachet contains 2 unhooking keys



Use	Caps for Line 4 Connectors	
Code	IS51400	IS52400
ID number	KXCSTAF	KXCSTAM
Connector type	Female	Male
Admitted working temperature range	- 40° < T < +90°	- 40° < T < +90°
Degree of protection	IP67	IP67
Flammability class	UL94-V0	UL94-V0
Quantity per package	50	50
Packaging	One packet contains 50 caps	

Cabur Solar connectors

Joint with MC connectors

When the short (40 mm) rubber mobile Line 3 connectors exit from the photovoltaic panel, connection must be done using Cabur IS15240 and IS25241 mobile connectors, both provided with IS15000 retention hooks, which ensure proper hooking between the two photovoltaic connectors and is included in the package. When the male/female pair of rubber mobile Line 3 connectors exits from the photovoltaic panel, but long type (50 mm), it is necessary to connect them using a pair of Cabur IS15242 and IS25243 mobile connectors, along with IS15001 long retention hook, included in the package. Finally, if the pair of MC4 Line mobile connectors exits the panel,

the connection should be performed using the pair of Cabur mobile connectors IS14240 and IS24241 (see figure below). In regards to connection to Inverters and/or StringBoxes in the case in which the male and female pair of connectors from the MC3 Line panel are combined, it is necessary to use Cabur IS15341 and IS25342 mobile connectors. If the panel connectors are from the MC4 line, it is necessary to use a pair of Cabur IS14240 and IS24241 mobile connectors. For connection with TYCO mobile connectors exiting from the panels, procure the male and female with the same polarity as indicated in the figures below.

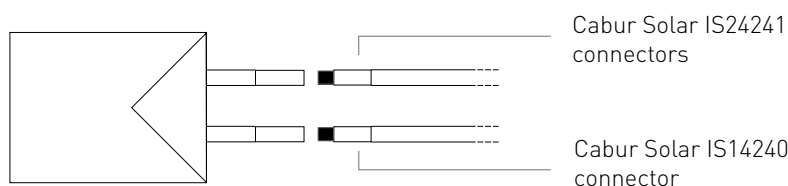
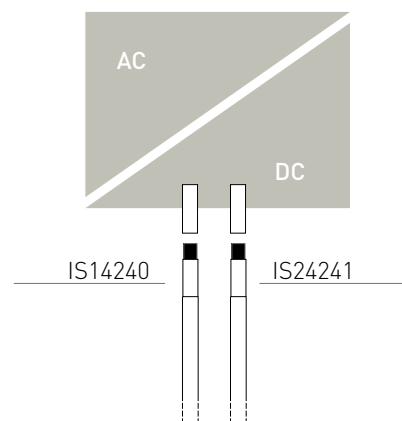
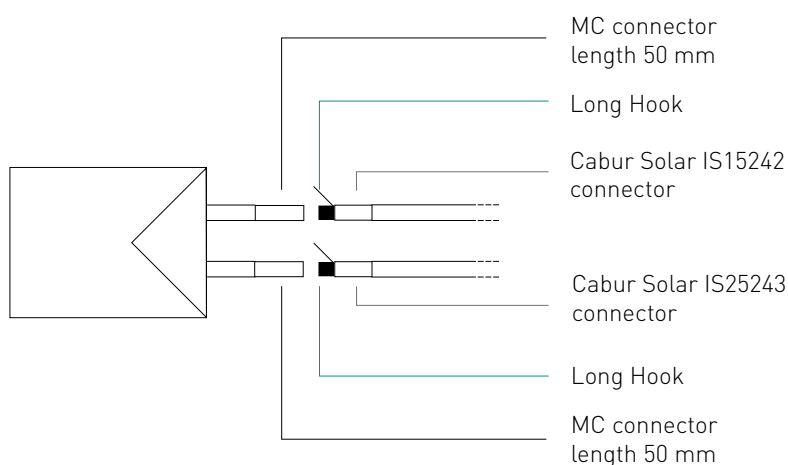
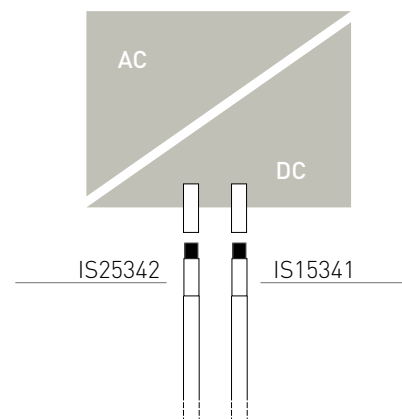
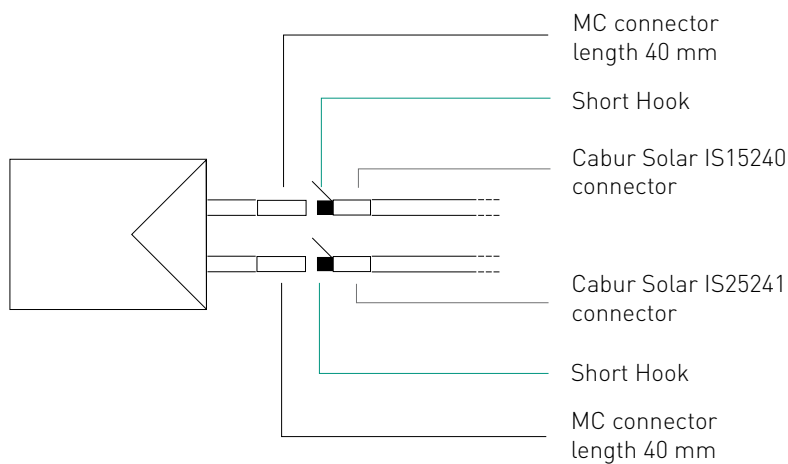

Solarlok® connectors

For connection to Inverter and photovoltaic panels equipped with TYCO connectors

Solarlok® articles create a flexible, easy-to-use system for reliable interconnections between photovoltaic modules and the inverter. The entire concept is based on the reliable and efficient management of the individual components of the interconnection system.

The security of the coupling is guaranteed by the polarised key closure, shaped and silver plated contacts to be crimped, and a connection system with release on the application of

pressure. In addition, the wide working temperature range and conformity to world standards for photovoltaic connections systems makes these products strong and reliable.

Apart from the 4 and 6 mm² connectors, the Cabur offer includes a set of professional tools, for specific use with Solarlok connectors and a first-installation KIT complete with all necessary accessories for connecting a photovoltaic system.



Technical features

- Secure coupling achieved using coded keys
- Multiple insertion and removal cycles
- Wide operating temperature range
-40 °C < T < +90 °C
- TÜV and UL approved
- Continuous 1000 DC voltage
- Continuous 25A current
- IP 67 protection degree

Solarlok Connectors®

For connection to Inverter and photovoltaic panels equipped with TYCO connectors



Normal packaging: the code refers to packets composed of plastic and metal parts (outer shell + PIN)

Application	For connection to photovoltaic panels (to create simple joints and/or extensions use male and female connectors with the same polarity)		For connection to photovoltaic panels (to create simple joints and/or extensions use male and female connectors with the same polarity)		For connection to female connectors, both positive and negative
Code	IS401394462	IS301394461	IS301394462	IS401394461	IS261394461
ID number	KXSUN04FPNEG	KXSUN04MPPPOS	KXSUN04FPPPOS	KXSUN04MPNEG	KXSUN04MPNEU
Application	Mobile connector	Mobile connector	Mobile connector	Mobile connector	Mobile connector
Polarity	Negative	Positive	Positive	Negative	Positive-Negative
Connector type	Female	Male	Female	Male	Male
PIN diameter	2.5 mm	2.5 mm	2.5 mm	2.5 mm	2.5 mm
Section of crimpable wires	4 mm ²	4 mm ²	4 mm ²	4 mm ²	4 mm ²
Pliers	UMCT3149	UMCT3149	UMCT3149	UMCT3149	UMCT3149
Matrix	IS3152	IS3152	IS3152	IS3152	IS3152
Features of metallic PIN	Tin-plated copper	Tin-plated copper	Tin-plated copper	Tin-plated copper	Tin-plated copper
Contact resistance:	Rc < 5 mΩ	Rc < 5 mΩ	Rc < 5 mΩ	Rc < 5 mΩ	Rc < 5 mΩ
PIN type	Shaped	Shaped	Shaped	Shaped	Shaped
Shell features	Plastic (PPO)	Plastic (PPO)	Plastic (PPO)	Plastic (PPO)	Plastic (PPO)
Maximum applicable voltage	1000 DC	1000 DC	1000 DC	1000 DC	1000 DC
Maximum applicable current	25 A	25 A	25 A	25 A	25 A
Admitted working temperature range	- 40° < T < +90°	- 40° < T < +90°	- 40° < T < +90°	- 40° < T < +90°	- 40° < T < +90°
Degree of protection	IP67	IP67	IP67	IP67	IP67
Flammability class	UL94-V0	UL94-V0	UL94-V0	UL94-V0	UL94-V0
Certifications obtained	TÜV & UL	TÜV & UL	TÜV & UL	TÜV & UL	TÜV & UL
Quantity per package	100	100	100	100	100
Packaging	Every packet contains 100 plastic shells and 100 metallic contacts (PINS)		Every packet contains 100 plastic shells and 100 metallic contacts (PINS)		Every packet contains 10 plastic shells and 10 metallic contacts (PINS)

Solarlok Connectors®

For connection to Inverter and photovoltaic panels equipped with TYCO connectors



Normal packaging: the code refers to packets composed of plastic and metal parts (outer shell + PIN)

Application	On StringBox and/or inverter		For connection to photovoltaic panels (to create simple joints and/or extensions use male and female connectors with the same polarity)		For connection to female connectors, both positive and negative
Code	IS301394738	IS401394738	IS651394462	IS651394461	IS461394461
ID number	KXSUNDCAC4POS	KXSUNDCAC4NEG	KXSUN06FPNEG	KXSUN06MPPPOS	KXSUN06MPNEU
Application	Panel	Panel	Mobile connector	Mobile connector	Mobile connector
Polarity	Positive	Negative	Negative	Positive	Positive-Negative
Connector type	Male	Male	Female	Male	Male
PIN diameter	2.5 mm	2.5 mm	2.5 mm	2.5 mm	2.5 mm
Section of crimpable wires	4 mm ²	4 mm ²	6 mm ²	6 mm ²	6 mm ²
Pliers	UMCT3149	UMCT3149	UMCT3149	UMCT3149	UMCT3149
Matrix	IS3152	IS3152	IS3152	IS3152	IS3152
Features of metallic PIN	Tin-plated copper	Tin-plated copper	Tin-plated copper	Tin-plated copper	Tin-plated copper
Contact resistance:	Rc < 5 mΩ	Rc < 5 mΩ	Rc < 5 mΩ	Rc < 5 mΩ	Rc < 5 mΩ
PIN type	Shaped	Shaped	Shaped	Shaped	Shaped
Shell features	Plastic (PPO)	Plastic (PPO)	Plastic (PPO)	Plastic (PPO)	Plastic (PPO)
Maximum applicable voltage	1000 DC	1000 DC	1000 DC	1000 DC	1000 DC
Maximum applicable current	25 A	25 A	25 A	25 A	25 A
Admitted working temperature range	- 40° < T < +90°	- 40° < T < +90°	- 40° < T < +90°	- 40° < T < +90°	- 40° < T < +90°
Degree of protection	IP67	IP67	IP67	IP67	IP67
Flammability class	UL94-V0	UL94-V0	UL94-V0	UL94-V0	UL94-V0
Certifications obtained	TÜV & UL	TÜV & UL	TÜV & UL	TÜV & UL	TÜV & UL
Quantity per package	100	100	100	100	100
Packaging	Every packet contains 10 plastic shells and 10 metallic contacts (PINS)		Every packet contains 100 plastic shells and 100 metallic contacts (PINS)		Every packet contains 100 plastic shells and 100 metallic contacts (PINS)



Tyco Electronics
Authorized Distributor



Normal packaging: the code refers to packets composed of plastic and metal parts (outer shell + PIN)

For connection to photovoltaic panels (to create simple joints and/or extensions use male and female connectors with the same polarity)		For the creation of parallels between strings		For the creation of parallels between strings	
IS551394462	IS661394461	IS101534611	IS201534611	IS101740277	IS201740277
KXSUN06FPP0S	KXSUN06MPNEG	KXSUNPOSSMM	KXSUNNEGSM	KXSUNPOSPFM	KXSUNNEGPFM
Flying connector	Mobile connector	Mobile connector	Mobile connector	Mobile connector	Mobile connector
Positive	Negative	Positive	Negative	Negative	Negative
Female	Male	Male/Male-Male	Male/Male-Male	Female/Male-Male	Female/Male-Male
2.5 mm	2.5 mm	2.5 mm	2.5 mm	2.5 mm	2.5 mm
6 mm ²	6 mm ²	4 mm ² and 6 mm ²	4 mm ² and 6 mm ²	4 mm ² and 6 mm ²	4 mm ² and 6 mm ²
UMCT3149	UMCT3149	NO	NO	NO	NO
IS3152	IS3152	NO	NO	NO	NO
Tin-plated copper	Tin-plated copper	Tin-plated copper	Tin-plated copper	Tin-plated copper	Tin-plated copper
Rc < 5 mΩ	Rc < 5 mΩ	Rc < 5 mΩ	Rc < 5 mΩ	Rc < 5 mΩ	Rc < 5 mΩ
Shaped	Shaped	Shaped	Shaped	Shaped	Shaped
Plastic (PPO)	Plastic (PPO)	Plastic (PPO)	Plastic (PPO)	Plastic (PPO)	Plastic (PPO)
1000 DC	1000 DC	1000 DC	1000 DC	1000 DC	1000 DC
25 A	25 A	25 A	25 A	25 A	25 A
- 40° < T < +90°	- 40° < T < +90°	- 40° < T < +90°	- 40° < T < +90°	- 40° < T < +90°	- 40° < T < +90°
IP67	IP67	IP67	IP67	IP67	IP67
UL94-V0	UL94-V0	UL94-V0	UL94-V0	UL94-V0	UL94-V0
TÜV & UL	TÜV & UL	TÜV & UL	TÜV & UL	TÜV & UL	TÜV & UL
100	100	100	100	100	100

Every packet contains 100 plastic shells and 100 metallic contacts (PINS)

Every sachet contains 10 Y joints

Every sachet contains 10 Y joints

Connection to connectors

Connection with Cabur Solar Y joints

Y joints are particularly useful for coupling the strings of panels in amorphous technology (thin film), where there are often parallel joints on the line leading to the inverter. They are therefore connections with low current and high voltage, typical with thin film.

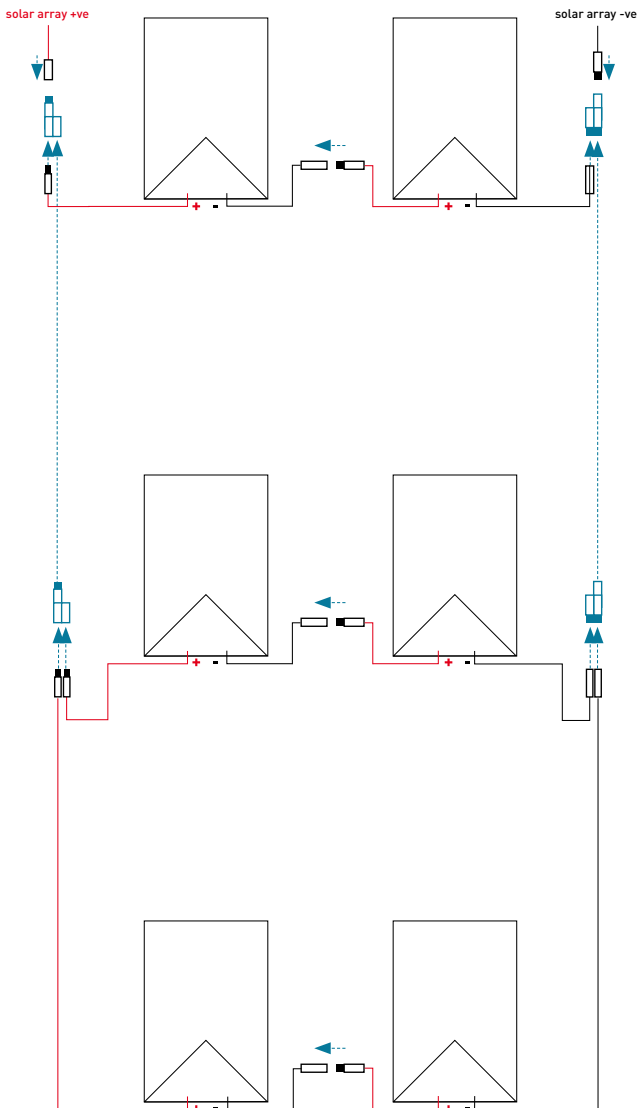

Connection Tyco mobile connectors

For connection with TYCO mobile connectors exiting from the panels, procure the male and female with the same polarity as indicated in the figures below.

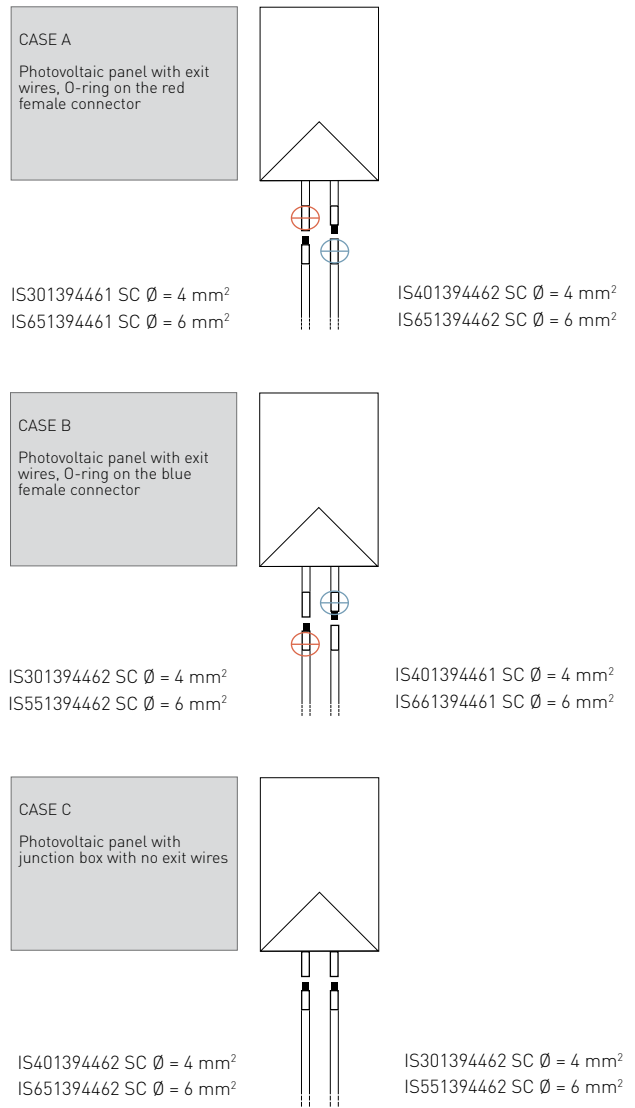

Tool

For perfect photovoltaic connections

To guarantee a result conforming to standard, in terms of the security of the connection and insulation degree, it is important to use suitable tools, according to the type of wire and connectors used.

Cabur wire strippers and crimpers are especially chosen to perform the specific operations with ease, in safety and

according to the technical requisites of the most efficient photovoltaic systems.

To ensure the efficacy of the guarantee, the use of Cabur Solar tools, in conformance with the standards and instructions found in Cabur official documentation, is an essential requirement.



Code	IS31579002
ID number	KXCSSLPE
Description	Cabur Solar wire stripper
Pieces CF	One



Code	UMCT3149
ID number	UMCT
Description	Crimper with interchangeable matrix (select matrix according to use)
Pieces CF	One
Accessories	see next page



Code	IS3170
ID number	IS3170
Description	Pocket Cabur Solar wire stripper
Pieces CF	One
Accessory	Spare blade code IS3170L



Code	IS3161
ID number	KXCRI2506
Description	Crimper for Cabur Solar connectors with matrices for wires with 2.5 - 4 or 6 mm ² sections.
Pieces CF	One



Code	IS211579002
ID number	KXSUNSPESPE
Description	Solarlok [®] wire strippers by Tyco Electronics
Pieces CF	One



Code	IS301102855
ID number	KXSUNESTRAT
Description	Solarlok Extractor [®]
Pieces CF	One

SOLARLOK[®]; TE and Tyco Electronics are registered trademarks.

Advantages of Cabur crimpers

Fixed matrix crimper IS3161

1. Recommended for simple and quick crimping
2. Tool for small systems

Interchangeable matrix crimper UMCT3149

1. Ideal for high-precision photovoltaic crimping, thanks to a lateral locating device that ensures correct positioning of the PIN and the form of the clamping indentations for perfect crimping
2. Thanks to the interchangeable matrices, it can also be used to crimp grommets, forks, ferrules, and other wire terminals

Advantages of Cabur wire strippers

Wire stripper IS31579002

1. It's well-built and robust, appropriate for thousands of cycles
2. It acts simultaneously on both the sleeves of the photovoltaic wire, cutting them precisely
3. Allows for precise calibration of the stripping length, thanks to an adjustable mobile cursor
4. The blades exert a defined cutting pressure, that is, they limit themselves to protect the strands
5. They can also be used to strip other wires

Wire stripper IS3170

1. Light, affordable, and pocket-sized

Tool

Matrices for crimper UMCT3149



Code	IS3152
ID number	IS3152
Contact types	Solarlok® by Tyco Electronics
Section Wire	2.5 - 4 or 6 mm ²
Pieces CF	One



Code	IS3153
ID number	IS3153
Contact types	Cabur Solar Line 3
Section Wire	2.5 - 4 or 6 mm ²
Pieces CF	One



Code	IS3154
ID number	IS3154
Contact types	Cabur Solar Line 4
Section Wire	2.5 - 4 or 6 mm ²
Pieces CF	One



The following matrices are also available for the UMCT crimper:

- for ferrules from 0.2 to 10 mm² - code UMCT3127
- for ferrules from 16 to 25 mm² - code UMCT3153
- for ferrules from 35 to 50 mm² - code UMCT3154
- for eyelets and forks from 1.5 to 2.5 mm² - code UMCT3129
- for eyelets and forks from 4 to 6 mm² - code UMCT3128

SOLARLOK®; TE and Tyco Electronics are registered trademarks.

Wire Stripping

Technical Standard CEI EN 60352-2 (Stapled connections - General rules, test methods and practical guide) leads to a stripped length of about 8 mm for our PIN contracts on both Line 3 and Line 4. Appropriate use of Cabur wire strippers guarantees optimal stripping (see instructions below).

Crimping with UMCT3149

The UMCT3149 crimper is designed for high precision photovoltaic crimping and therefore has a lateral positioner which ensures correct positioning of the PIN. The positioner is screwed onto all the matrices and, if necessary, can be removed. The geometry of the clamping indentations ensures highly effective crimping. Thanks to the interchangeable matrices, the **UMCT3149** can also be used for crimping grommets, forks, ferrules, and other wire terminals used for normal wiring of electrical panels and for automation. For matrix substitution, please see the diagram on the next

page. Thanks to the marks on the matrix, it's easy to correctly position the PIN for each contact: the wire section is indicated on the lower part and the PIN diameter on the upper part. Every matrix gives a specific crimp. Let's see which, using the example case of matrix **IS3153** for the PIN Cabur Solar Line 3 (the use of matrices IS3154 for the PIN Cabur Solar Line 4 and IS3152 for PIN Solarlok® is similar).

With matrix **IS3153**, it is possible to crimp **only Line 3 PINS**, on all wire sections, using:

- the first indentation on the right is for the wire with a 2.5 mm² section;
- the second indentation in the middle is for the wire with a 4 mm² section;
- the third indentation on the left is for the wire with a 6 mm² section.

Tool

Recommendations for correct use

How to strip wire using IS31579002



1. The wire stripper works like a guillotine, suitable for wires of various thicknesses, allowing for fast and safe stripping.
2. It acts simultaneously on both the sleeves of the photovoltaic wire, cutting them precisely.
3. The blades move parallel to the wire, expelling the sheared off sleeve.

Stripping with IS3170

This wire stripper is able to strip wires with sections of 2.5, 4, 6 and 10 mm². It is fitted with an end stop and allows for a stripped constant length of approx. 8 mm, compliant with the requirements of our PINS. The blade can be replaced.

- To strip wires with a 2.5 mm² section, the blade must make a complete turn around the external perimeter of the wire.
- To strip wires with a 4 mm² section, the blade must make two complete turns around the external perimeter of the wire.
- To strip wires with a 6 mm² section, the blade must make three complete turns around the external perimeter of the wire.

In order to preserve the number of strands, the blade should not be turned more times than those indicated in the recommendations above for each wire section.

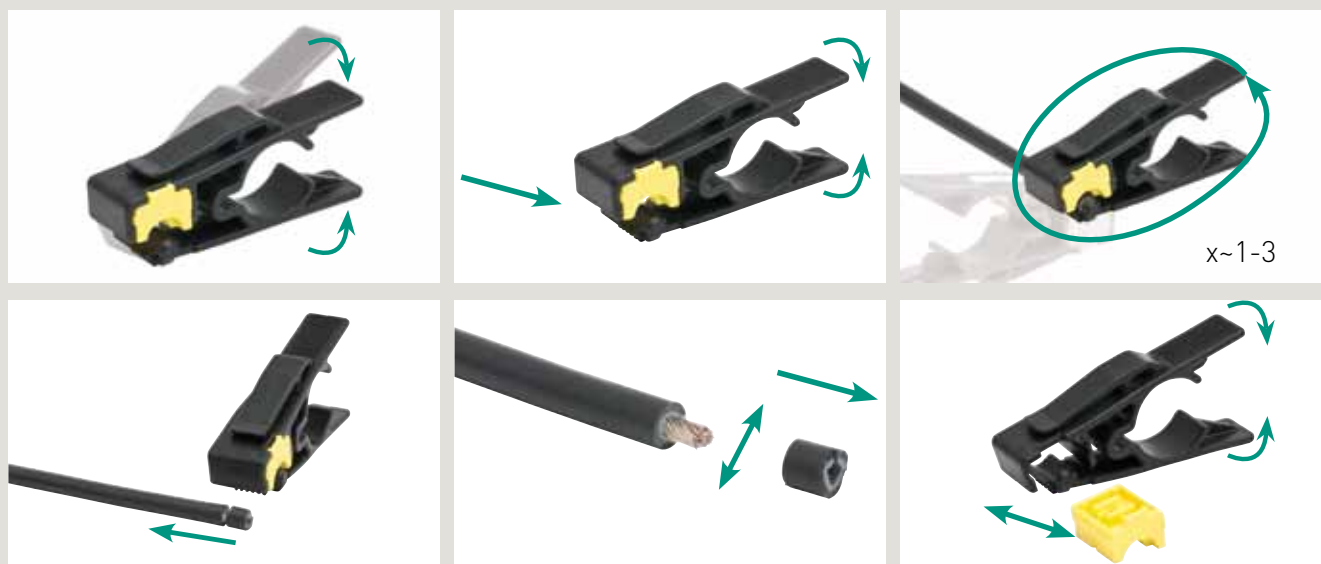

Tool

Recommendations for correct use

How to crimp



Example of use of the IS3161 crimper for Cabur Solar connectors.

How to change the UMCT Crimper matrix

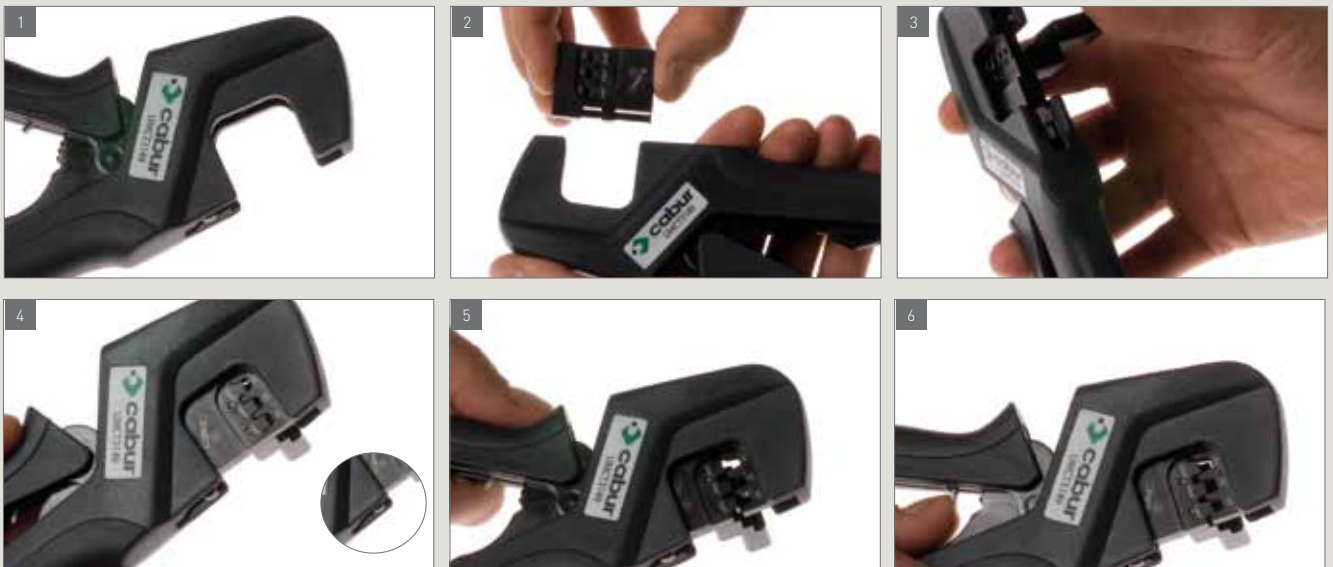

- Open the pliers as wide as possible (fig. 1);
- slowly bring the two levers of the pliers together, until the locking/release mechanism makes three clicks (fig. 2);
- observe the anchorage pin on the matrix (fig. 2);
- insert the matrix, moving the anchorage pin towards the internal part of the pliers chamber (fig.3);
- make sure that the plastic tooth has locked the matrix in place or that it has risen (fig.4);
- press the two levers of the pliers, closing them as tightly as possible (fig.4);
- release the handles; the pliers should open automatically and completely (fig.5);
- if, when the pliers are closing, you realise that the crimping is not successful or the crimper is blocked for any reason, pressure can be released by pressing and releasing the handles a few times and simultaneously pressing with your thumb on the release lever on the internal part of the handle (fig.6).

First installation kit

Cabur Solar Line 3, 4, and Solarlok®

- The first-installation KIT ISKIT03A includes a selection of Cabur Solar Line 3 photovoltaic connectors and the necessary tools for properly crimping photovoltaic wires with 2.5 mm², 4 mm², and 6 mm² sections.
- The first-installation KIT ISKIT04 includes a selection of Cabur Solar Line 4 photovoltaic connectors and the necessary utensils for properly crimping photovoltaic wires with 4 mm², and 6 mm² sections.
- The first-installation KIT ISKITYCO contains a selection of photovoltaic connectors from the Solarlok® line by Tyco™ and the necessary tools for crimping photovoltaic wires with 4 mm² and 6 mm² sections.

The contents of each kit can be seen in the table below. Every kit is contained in a professional tool box, and does not include the wires.

Any other tools not included, can be added to the Kit. Technical details of the single components are given on the relative pages.



CODE ISKIT03A			CODE ISKIT04			CODE ISKITYCO		
ID number SUNKIT03A			ID number SUNKIT04			ID number SOLARBOX		
Kit composition			Kit composition			Kit composition		
Code	ID number	Pieces CF	Code	ID number	Pieces CF	Code	ID number	Pieces CF
IS15240	KX03VM2540GC	20	IS14240	KX04VM4060	20	IS261394461	KXSUN04MPNEU	40
IS25241	KX03VF2540GC	20	IS24241	KX04VF4060	20	IS301394462	KXSUN04FPPOS	20
IS13112	KX03PM4060	10	IS14110	KX04PM4060	10	IS401394462	KXSUN04FPNEG	20
IS23113	KX03PF4060	10	IS24111	KX04PF4060	10	IS301102855	KXSUNESTRAT	1
IS41310S	KX03MFFGS	5	IS41410	KX04MFF	5	IS211579002	KXSUNSPESPE	1
IS42320S	KX03FMMGS	5	IS42420	KX04FMM	5	UMCT3149	UMCT	1
UMCT3149	UMCT	1	UMCT3149	UMCT	1	IS3152	IS3152	1
IS3153	IS3153	1	IS3154	IS3154	1	-	-	-

Wires

For photovoltaic systems both small and large

- Single pole wire with flexible conductor in tin-plated copper class 5
- First HEPR insulation type G21 special
- Second Halogen Free Type Elastometric blend insulation M21
- For specific use with photovoltaic systems with nominal voltage of $U_0/U = 600/1000$ AC under alternating current and not exceeding $U_0/U = 900/1500$ DC under direct current
- Non-flame propagating
- Halogen free
- Designed for a useful lifetime of at least 25 years
- Resistant to UV rays, water, ozone, salts, fluids, and atmospheric agents in general
- Standard colours Black and Red

IMQ certified wires - FG21M21

Code	ISCS02100	ISCS02101	ISCS02500	ISCS02501	ISCS04100	ISCS04101	ISCS04400
ID number	KXCSOL2N100	KXCSOL2R100	KXCSOL2N500	KXCSOL2R500	KXCSOL4N100	KXCSOL4R100	KXCSOL4N400
Section	2.5 mm ²	2.5 mm ²	2.5 mm ²	2.5 mm ²	4 mm ²	4 mm ²	4 mm ²
Colour	Black	Red	Black	Red	Black	Red	Black
Packaging type	Skein	Skein	Spool	Spool	Skein	Skein	Spool
Length	100 m	100 m	500 m	500 m	100 m	100 m	400 m
Code	ISCS04401	ISCS06100	ISCS06101	ISCS06300	ISCS06301	ISCS10200	ISCS10201
ID number	KXCSOL4R400	KXCSOL6N100	KXCSOL6R100	KXCSOL6N300	KXCSOL6R300	KXCSOL10N200	KXCSOL10R200
Section	4 mm ²	6 mm ²	6 mm ²	6 mm ²	6 mm ²	10 mm ²	10 mm ²
Colour	Red	Black	Red	Black	Red	Black	Red
Packaging type	Spool	Skein	Skein	Spool	Spool	Spool	Spool
Length	400 m	100 m	100 m	300 m	300 m	200 m	200 m

TÜV certified wires - PV1 - F

Code	ISCS02100T	ISCS02101T	ISCS02500T	ISCS02501T	ISCS04100T	ISCS04101T	ISCS041000T
ID number	KXCSOL2N100T	KXCSOL2R100T	KXCSOL2N500T	KXCSOL2R500T	KXCSOL4N100T	KXCSOL4R100T	KXCSOL4N1000T
Section	2.5 mm ²	2.5 mm ²	2.5 mm ²	2.5 mm ²	4 mm ²	4 mm ²	4 mm ²
Colour	Black	Red	Black	Red	Black	Red	Black
Packaging type	Skein	Skein	Spool	Spool	Skein	Skein	Spool
Length	100 m	100 m	500 m	500 m	100 m	100 m	1000 m
Code	ISCS041001T	ISCS06100T	ISCS06101T	ISCS061000T	ISCS061001T	ISCS10100T	ISCS10101T
ID number	KXCSOL4R1000T	KXCSOL6N100T	KXCSOL6R100T	KXCSOL6N1000T	KXCSOL6R1000T	KXCSOL10N100T	KXCSOL10R100T
Section	4 mm ²	6 mm ²	6 mm ²	6 mm ²	6 mm ²	10 mm ²	10 mm ²
Colour	Red	Black	Red	Black	Red	Black	Red
Packaging type	Spool	Skein	Skein	Spool	Spool	Skein	Skein
Length	1000 m	100 m	100 m	1000 m	1000 m	100 m	100 m

The following are available on-demand:

- 1.5 mm² section wires
- Wires with sections from 16 to 240 mm
- IMQ certified wires with sections from 4 to 6 mm² in 1,000 m spools

- Wires with 10 mm² sections in 1,000 m spools (certified IMQ or TÜV)
- UL wires
- Blue wires

For times, minimum quantities, and packaging costs, contact the Cabur Sales Office.

Pre-wired cables

To connect the panels within the string, Cabur offers a range of solutions composed of Line 3 and Line 4 mobile connectors on black and red 4mm² and 6mm² wires.

Any other combination of section, colour, length and type of final connector is available in any quantity you need. For a customised quote contact the Cabur sales network.

Technical characteristics for FG21M21 IMQ certified wires

- Continuous working temperature: $-40^{\circ} + 90^{\circ}\text{C}$
- Maximum working temperature of the metallic core: 90°C
- Minimum working temperature: -25°C
- Temperature peak: 250°C
- Lifetime: 25 years, provided that the temperature of the metallic core never exceeds 90°C
- Test voltage in alternate current: 6.500 V
- Test voltage in direct current: 15.000 V
- Minimum radius curve: 4 times external diameter
- Breakage point under traction: 50 N/mm²
- Standard colours: Black, Red

Approvals

- IMQ
- Conforming to RoHS

Flexible conductor made of tin-plated copper, class 5, conforming to CEI 60227

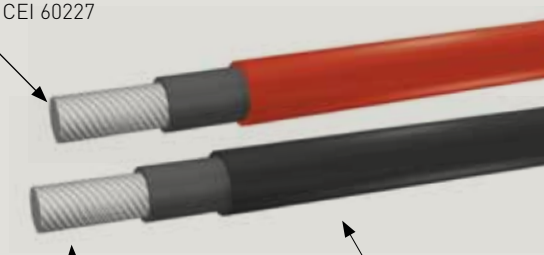

1st insulation: HEPR type G21 special

2nd insulation: Elastometric compound Halogen Free type M21

Laboratory tests carried out by IMQ for wire certifications

Electrical tests

Conductor electrical resistance	EN 50395 art. 5
Voltage tests on finished wires	EN 50395 art. 6
Flaw-free insulation	EN 50395 art. 10
Sleeve surface resistance	EN 50395 art. 11
Insulation resistance on complete wire	CEI 20-13 art. 3.2.03
- at 20°C	
- at 90°C	
Stability under direct current	EN 50305 art. 6.7

Verification of construction and dimension prescriptions

Verification of conformance to prescriptions	Visual exam of construction and manual tests
Measurement of insulation thickness	EN 50396 art. 4.1
Measurement of sleeve thickness	EN 50396 art. 4.2
Measurement of external dimensions:	EN 50396 art. 4.4
- average value	
- ovalisation	

Mechanical properties of insulation

Traction resistance test before ageing	EN 60811-1-1
Traction resistance test after ageing	EN 60811-1-2
Lengthening under heat	EN 60811-2-1
Water absorption test	EN 60811-1-3

Mechanical properties of sleeve

Traction resistance test before ageing	EN 60811-1-1
Traction resistance test after ageing	EN 60811-1-2
Lengthening under heat	EN 60811-2-1
Water absorption test	EN 60811-1-3

Compatibility test

EN 60811-1-2

Tests at low temperature

Sleeve bending test	EN 60811-1-4 art. 8.1
Sleeve lengthening test	EN 60811-1-4 art. 8.2
Shock resistance test	EN 60811-1-4 art. 8.5

Ozone resistance test

EN 50395 art. 8.1.3

UV rays resistance test

HD 605/A1 art.2.4.20

Fire behaviour

CEI 20-35/1-2

Evaluation of halogens

Determination of HCl quantity	CEI 20-37/2-1
Determination of gas corrosiveness	CEI 20-37/2-2



Technical characteristics of PV1-F wires certified TÜV

- Working temperature: -40°C + 90°C
- Max. short circuit temperature: +200°C (5s max)
- Lifetime: 25 years
- Test voltage in alternate current: 6.500 V
- Test voltage in direct current: 15.000 V
- Uo/U nominal voltage: 0.6/1 kV AC; 1.8kV DC
- Minimum radius curve:
 - mobile installation 15 x wire diameter
 - fixed installation 6 x wire diameter
- Insulation resistance: >1014 Ω x cm at 20°C
- Standard colours: Black, Red

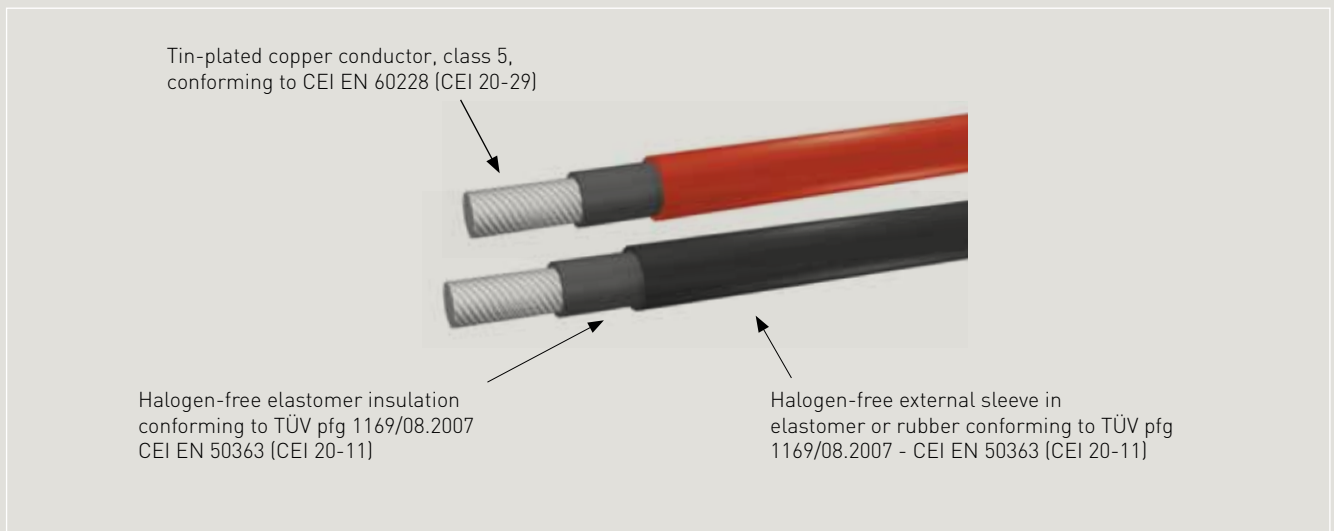

Laboratory tests carried out by TÜV for wire certifications

Reference regulations: TÜV 2 Pfg 1169/08.2007

Ozone resistance	EN 50396 art. 8.1.3
Resistance to UV rays	HD605/A1 part 2.4.20
Vertical flame propagation test	CEI EN 60332-1-2
High temperature pressure test on complete wire	EN 60811-3-1
Halogen content	CEI EN 50267-2-1 CEI EN 50267-2-2 EN 6084-2
Electrical resistance	CEI 20-29 EN60228 CL.5



StringBox

Connection panels for photovoltaic panel strings

The connection panels of the StringBox series are designed and constructed according to Standard CEI 82-25.

This is a real solution for the various needs of this sector, which takes into due consideration the need for customised products.

The panels are available in 1, 2, 3, 4, 6 and 8 strings versions and include all components necessary for protection and for parallel connection of the strings of photovoltaic panels.

All components are already wired with special PV wire, therefore in the case of electrical panels with connector input, the Customer must simply connect the same and provide for earth wiring and output towards the inverter, with considerable saving both in the management of the components and in installation.

The illustration below shows an example of the components that can be inserted into the cabinet.

Box for external use, made of high-quality UV resistant polycarbonate, with IP66 protection.

Fuse holders 10.3 x 38 approved UL 1,000 DC. The fuse holders are found in the boxes of 4, 6, and 8 strings and are used to disconnect the string in the case of malfunction, short circuit, or a short in one of the connections.

Generally panels with 2 and 3 strings are not provided with fuse holders, as the maximum current generated by one or two strings is not sufficient to ensure safe intervention of the fuse in the case of malfunction on a string. Fuses should be chosen and ordered by the customer based on the string current value.

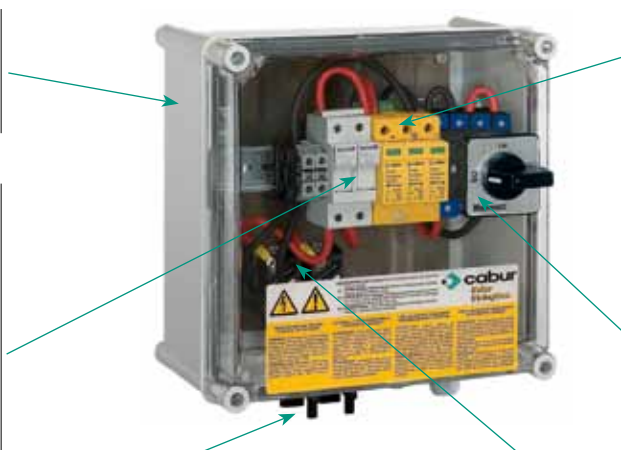

Surge protection devices 20 kA (8/20), Ures ≤ 1.5 kV, available in voltages 500 DC, 600 DC, 800 DC, and 1000 DC for better coordination with the voltage effectively generated by the system.

Disconnecter in DC-21A Approved UL at 1 kDC, available for nominal currents 40A and 63A, as requested by CEI 82-25, it is as approved as a disconnecter under load and allows the voltage generated by the strings to be disconnected so that downstream interventions can be carried out from the SolarBox electrical panel in complete safety.

Connectors for special photovoltaic wires, with IP67 protection, they also include a mechanical locking mechanism to prevent accidental unhooking.

Diodes are used to impede the voltage of the normally operating strings from circulating to "shaded" or malfunctioning strings, or to those whose generation capacity is decreasing. They are available as standard

versions. The diodes are fitted on aluminium plates to dissipate the heat generated by the current which runs through them. **WARNING:** CEI 82-25 recommends that the diode be used for electrical panel with 3 or more strings.

Advantages of the StringBox series

1. Fast installation: components are already wired, able to connect using extractable connectors
2. Standard product, in conformance with the regulations in effect: ideal to minimise design and inspection times and costs
3. Quality components in conformance with the regulations in effect
4. Large product range able to satisfy a wide range of needs
5. Electrical panel assembly completed and inspected by qualified personnel

The range is divided into three series

Standard: the most commonly used models, which include panels for systems with earthed positive and negative, and for systems with earthed negative; normally managed by the warehouse (see pages 40 and 41)

Special: models which satisfy less common needs; including panels with earthed positive pole and panels with modifications which can be derived from standard panels; for codes and sales conditions, please contact our sales network

Custom: StringBox for specific needs, which Cabur constructs at the Customer's request, not included in the above categories. For information, please contact our sale network

Standard StringBox

with fuses at both poles for earthed panels

Panels for strings with fuse holders on both poles, suitable for systems with both poles earthed; also usable in systems with one earthed pole, inserting small short-circuit protection cylinders instead of the fuses of the common earthed poles. Produced in versions with or without diodes, string input by means of solar connectors (models KX04PM4060 and

KX04PF4060) for wires of 4 mm² and 6 mm². The fuse holders do not have fuses, which must be chosen and ordered by the customer according to the string current (see page 58). Special versions can be constructed on request, with string input through sire glands and/or 500 DC surge protection devices.

Version with diode

Code	Nominal U/I cabinet	N° Strings	UCmax /UDC STC Limit device	Dimensions (LxHxW)
ISB02HDCA06	40A 480DC	2	600/1200V	300x300x180
ISB02HDCA08	40A 690DC	2	800/1600V	300x300x180
ISB02HDCA10	40A 690DC	2	1000/2000V	300x300x180
ISB03HDCA06	40A 480DC	3	600/1200V	300x300x180
ISB03HDCA08	40A 690DC	3	800/1600V	300x300x180
ISB03HDCA10	40A 690DC	3	1000/2000V	300x300x180
ISB04HDCA06	40A 480DC	4	600/1200V	450x450x180
ISB04HDCA08	40A 690DC	4	800/1600V	450x450x180
ISB04HDCA10	40A 690DC	4	1000/2000V	450x450x180
ISB06HDCA06	63A 480DC	6	600/1200V	540x360x180
ISB06HDCA08	63A 690DC	6	800/1600V	540x360x180
ISB06HDCA10	63A 690DC	6	1000/2000V	540x360x180
ISB08HDCA06	63A 480DC	8	600/1200V	540x540x180
ISB08HDCA08	63A 690DC	8	800/1600V	540x540x180
ISB08HDCA10	63A 690DC	8	1000/2000V	540x540x180

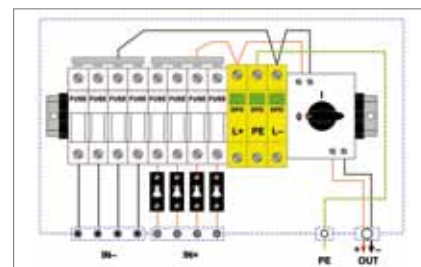

Example in photo and diagram of model ISB04HDCA06

Version without diode

Code	Nominal U/I cabinet	N° Strings	UCmax /UDC STC Limit device	Dimensions (LxHxW)
ISB01HXCA06	40A 480DC	1	600/1200V	300x300x180
ISB01HXCA08	40A 690DC	1	800/1600V	300x300x180
ISB01HXCA10	40A 690DC	1	1000/2000V	300x300x180
ISB02HXCA06	40A 480DC	2	600/1200V	300x300x180
ISB02HXCA08	40A 690DC	2	800/1600V	300x300x180
ISB02HXCA10	40A 690DC	2	1000/2000V	300x300x180
ISB03HXCA06	40A 480DC	3	600/1200V	300x300x180
ISB03HXCA08	40A 690DC	3	800/1600V	300x300x180
ISB03HXCA10	40A 690DC	3	1000/2000V	300x300x180
ISB04HXCA06	40A 480DC	4	600/1200V	450x450x180
ISB04HXCA08	40A 690DC	4	800/1600V	450x450x180
ISB04HXCA10	40A 690DC	4	1000/2000V	450x450x180
ISB06HXCA06	63A 480DC	6	600/1200V	540x360x180
ISB06HXCA08	63A 690DC	6	800/1600V	540x360x180
ISB06HXCA10	63A 690DC	6	1000/2000V	540x360x180
ISB08HXCA06	63A 480DC	8	600/1200V	540x540x180
ISB08HXCA08	63A 690DC	8	800/1600V	540x540x180
ISB08HXCA10	63A 690DC	8	1000/2000V	540x540x180

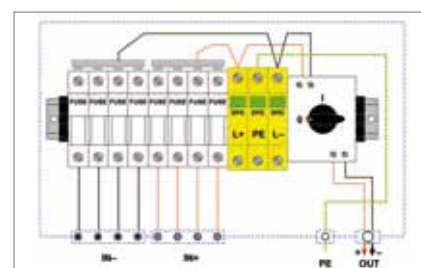

Example in photo and diagram of model ISB04HXCA06

Note: the limit device (or discharge device) must have a size such that it has a Uc voltage of at least 25% more than the Uoc (string voltage)

The range could vary and be expanded, even in the very near future, to effectively answer the needs of a rapidly evolving market; it is therefore advisable to check on possible updating at the website www.cabur.it.

Standard StringBox

with fuse on the positive for panels with earthed negative

String panels with fuse holder on positive pole suitable for systems with earthed negative pole. Produced in versions with or without diodes, string input by means of solar connectors (models KX04PM4060 and KX04PF4060) for wires of 4 mm² and 6 mm². The fuse holders do not have fuses, which must be

chosen and ordered by the customer according to the string current (see page 43). Special versions can be constructed on request, with string input through sire glands and/or 500 DC surge protection devices.

Version with diode

Code	Nominal U/I cabinet	N° Strings	UCmax /UDC STC Limit device	Dimensions (LxHxW)
ISB01FDCA06	40A 480DC	1	600/1200V	300x300x180
ISB01FDCA08	40A 690DC	1	800/1600V	300x300x180
ISB01FDCA10	40A 690DC	1	1000/2000V	300x300x180
ISB02FDCA06	40A 480DC	2	600/1200V	300x300x180
ISB02FDCA08	40A 690DC	2	800/1600V	300x300x180
ISB02FDCA10	40A 690DC	2	1000/2000V	300x300x180
ISB03FDCA06	40A 480DC	3	600/1200V	300x300x180
ISB03FDCA08	40A 690DC	3	800/1600V	300x300x180
ISB03FDCA10	40A 690DC	3	1000/2000V	300x300x180
ISB04FDCA06	40A 480DC	4	600/1200V	450x450x180
ISB04FDCA08	40A 690DC	4	800/1600V	450x450x180
ISB04FDCA10	40A 690DC	4	1000/2000V	450x450x180
ISB06FDCB06	63A 480DC	6	600/1200V	540x360x180
ISB06FDCB08	63A 690DC	6	800/1600V	540x360x180
ISB06FDCB10	63A 690DC	6	1000/2000V	540x360x180
ISB08FDCB06	63A 480DC	8	600/1200V	540x540x180
ISB08FDCB08	63A 690DC	8	800/1600V	540x540x180
ISB08FDCB10	63A 690DC	8	1000/2000V	540x540x180

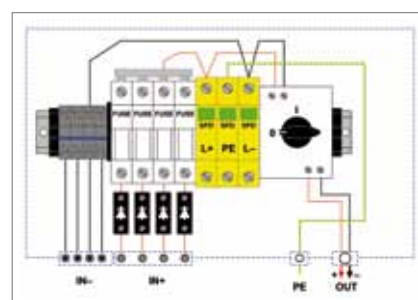

Example in photo and diagram of model ISB04FDCA06

Version without diode

Code	Nominal U/I cabinet	N° Strings	UCmax /UDC STC Limit device	Dimensions (LxHxW)
ISB01FXCA06	40A 480DC	1	600/1200V	300x300x180
ISB01FXCA08	40A 690DC	1	800/1600V	300x300x180
ISB01FXCA10	40A 690DC	1	1000/2000V	300x300x180
ISB02FXCA06	40A 480DC	2	600/1200V	300x300x180
ISB02FXCA08	40A 690DC	2	800/1600V	300x300x180
ISB02FXCA10	40A 690DC	2	1000/2000V	300x300x180
ISB03FXCA06	40A 480DC	3	600/1200V	300x300x180
ISB03FXCA08	40A 690DC	3	800/1600V	300x300x180
ISB03FXCA10	40A 690DC	3	1000/2000V	300x300x180
ISB04FXCA06	40A 480DC	4	600/1200V	450x450x180
ISB04FXCA08	40A 690DC	4	800/1600V	450x450x180
ISB04FXCA10	40A 690DC	4	1000/2000V	450x450x180
ISB06FXCB06	63A 480DC	6	600/1200V	540x360x180
ISB06FXCB08	63A 690DC	6	800/1600V	540x360x180
ISB06FXCB10	63A 690DC	6	1000/2000V	540x360x180
ISB08FXCB06	63A 480DC	8	600/1200V	540x360x180
ISB08FXCB08	63A 690DC	8	800/1600V	540x360x180
ISB08FXCB10	63A 690DC	8	1000/2000V	540x360x180

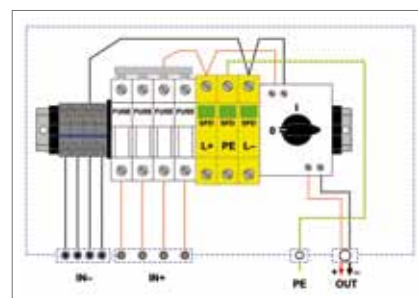

Example in photo and diagram of model ISB04FXCA06

Note: the limit device (or discharge device) must have a size such that it has a Uc voltage of at least 25% more than the Uoc (string voltage)

The range could vary and be expanded, even in the very near future, to effectively answer the needs of a rapidly evolving market; it is therefore advisable to check on possible updating at the website www.cabur.it.

SPDBox

Connection panels downstream of the inverter



The panels of the SPDBox series are designed and constructed according to Standards CEI 81-21 and 64-8.

The panels are available in the standard versions already containing the Surge Protection Devices on single phase lines, three phase lines and three phase lines with neutral for which customised configurations are possible on request, such as boxes with more free modules (to allow for the addition of a magneto-thermal switch) and with or without cable glands for wires entering or exiting the box.

- **Boxes** for external use, made of polycarbonate, with IP65 protection.
- **Surge protection devices** available in versions of 20 kA (8/20) U_{max}. 320AC 2 poles with spark gap measurement device for single phase voltages, of 40kA (8/20) U_{max}. 460AC 3 poles three phase voltages, 40kA (8/20) U_{max}. 460AC 3 poles with spark gap measuring device for three phase voltages with neutral.
- **Cable glands** for the IP65 exit of the connection wires.

Code	ISSAM05P	ISSBM05P	ISSBM08P	ISSCM05P	ISSCM08P
ID number	ISSAM05P	ISSBM05P	ISSBM08P	ISSCM05P	ISSCM08P
AC line type	Single phase	Three phase	Three phase	Three phase - Neutral	Three phase - Neutral
Box type	3 - 5 Modules	3 - 5 Modules	4 - 8 Modules	3 - 5 Modules	4 - 8 Modules
Busy modules	2	3	3	4	4
Free modules	3	2	5	1	4
Dimensions (LxHxD) mm	120x160x90	120x160x90	200x160x90	120x160x90	120x160x90

Surge protection devices for PV systems and DC voltages

Surge protection devices (SPD) prevent sudden electrical surges induced to the PV field by the earthed network and conducted to the AC power supply network or signal line from damaging the electronic equipment. The protection devices in the ISPD1455xBY7-40/3 series limit dangerous electrical

surges to normal levels tolerated by the devices recommended for use in Surge Category II (less than 4kV with U_{oc} 1,000DC) in Surge Protection Zone C, SPD Test Class II, as required by the IEC1024, IEC1312-1, and EN50083-1 regulations.

Where and how SPDs should be used

In the case of transitory power surges, the only way to protect equipment is to limit the difference in voltage between the various conductors that exit/enter the device. For this reason, in PV systems the surge protection must always be installed on both the AC and DC sides, so as to guarantee equal voltage between all the various system conductors, both in the case that the surge arrives from the PV field or from the AC or earthed network.

In the case of a power surge on the PV field, the DC side SPDs create an instantaneous short between the positive, negative, and earthed conductors, establishing a transitory voltage equilibrium. Hence the three conductors on the DC side of the inverter rise to thousands of V, but as the SPDs limit the difference in voltage between the three conductors to 4kV, no malfunctions will occur on the DC side of the inverter, which will have a resistance to impulse power surges greater than 4kV.

Alone, however, this is insufficient to protect the inverter from malfunctioning, because if the three conductors on the DC side rise to 10kV and on the AC side there are no SPDs able to create transitory voltage equilibrium with the DC side, then the DC side at 10kV will "see" the 230-400 AC exiting from the inverter as a lower voltage to which it can discharge through the insulation and/or components of the inverter, destroying them. Similarly, the same thing would occur if the power surge occurred on the AC side.

The concept of equal voltage requires the use of SPDs on all conductors that exit and enter the inverter, because only by limiting the difference in voltage between the AC and DC sides and the earthing, that is to say within the surge levels that the device is able to support, can destructive surges to the insulation or components be avoided.

Safe use of SPDs up to 1,000DC

The varistor, the active element of the SPD, is a component that is able to support a limited number of discharges. It can still short circuit if subjected to a discharge that exceeds its max I_{sc} , or if it is subjected to multiple discharges below its max I_{sc} , gradually deteriorating its performance. Under these conditions, its resistance, which normally is in tens of M Ω , will decrease to a few hundreds/tens of Ω , the varistor will overheat due to the passage of current between the line and the earthing, and it can catch fire.

Regulations regarding Test Class II SPDs requires them to be provided with a device which disconnects them from the line at the end of their useful life. The device consists of a contact in series on the side of the line which has its ends welded airtight, one of which is spring-loaded. When the overheated varistor exceeds the fusion temperature of the seal, the spring-loaded conductor disconnects, opening the contact and disconnecting the varistor from the line, thereby preventing damage.

In modern SPDs, created for use on AC lines, in which the disconnection device is able to eliminate the arc, during the pass to zero of the AC current, consequent to the opening of the broken varistor through which the short L/earthing current passes.

In PV systems the varying conditions make the automatic disconnection task of the SPDs more difficult. DC voltages from 500 to 1000 V and no pass to zero for the voltage/current makes interruption of the arc between the contacts at entry more difficult, because the air and surface distances designed for AC are not sufficient to guarantee disconnection power for the arc in DC. The problem is solved by using three varistors set up in a "Y" formation. With the Y set up, the discharge is divided into three varistors instead of the two found in the classic formation. This makes it much less likely that one of them will malfunction. Nevertheless, in the case of a short in one of the varistors, in the circuit between the Line and the earthing, once the surge has passed, the second intact varistor returns to the resistance M Ω , cutting off the current to the contact on the malfunctioning varistor.

Cabur does not recommend the use of earthed gas discharge devices on the DC side, because while they are able to ensure insulation in terms of earthing, in the case of a short or semi-short to a converter, the gas discharge device would not be set off by the DC voltage, meaning that the string I_{sc} would pass through the varistor, and it could catch fire.

Surge protection devices for PV systems and DC voltages

Construction characteristics of ISPD1455x BY7-40/3 series SPDs

These consist of a wiring base which can be assembled on a DIN guide and an extractable protection cartridge which contains the converter (VDR, Voltage Dependent Resistor), which makes it easy to disconnect the protection during insulation tests or for quick replacement when useful life has ended. ISPD1455x BY7-40/3 series SPD bases and cartridges are provided with a coding device that make it impossible to insert the wrong cartridge i.e. inserting 230AC in a 400AC base or vice versa.

ISPD1455x series SPDs are able to support 10 surges of I_{sc} 20kA impulse 8/20 and a single surge of 40kA, which

statistically is very rare.

ISPD1455x BY7-40/3 series SPDs are provided with an internal auto-disconnection thermal fuse device able to disconnect the varistor from the line in the case of malfunctioning, providing information about the malfunction visible on the front of the cartridge, and offering notification by switching an exchange contact which can be used as a remote signal. When an SPD has reached the end of its useful life, after several surges and years of service, it can be quickly replaced by extracting it from the base and replacing it with the same model without disconnecting the power supply.

SPD protective devices and fuses

The insertion of protective fuses on the main line or its terminal upstream from the SPD is a difficult problem, mainly due to the difficulty of coordinating the value of the fuse so as to be able to resist the discharge current without opening the circuit before the SPD has completed its task.

The problem is made more complex by the specific characteristics of PV fuses, as the fuse that ensures intervention to the string I_{sc} may not be able to resist the current of the discharge, and will burn before the SPD has completely eliminated the power surge.

Surge Protection Devices for direct current

The Surge Protection Devices (SPD) protect the photovoltaic system against excess voltage induced by atmospheric discharge (lightening) and protect the field side under direct current upstream of the inverter.

The range includes four models with intervene at 500 - 600 - 800 - 1000 V.

The features of each model are given in the table below.

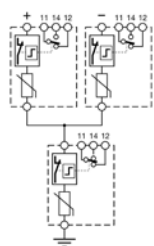

Code	ISPD14555	ISPD14556	ISPD14557	ISPD14558
ID number	BY7-40/3-500	BY7-40/3-600	BY7-40/3-800	BY7-40/3-1000
Use category	II	II	II	II
Earth system	-	-	-	-
Technology	MOV (Metal Oxide Varistor)	MOV (Metal Oxide Varistor)	MOV (Metal Oxide Varistor)	MOV (Metal Oxide Varistor)
Maximum direct voltage	Uc 500 DC	Uc 600 DC	Uc 800 DC	Uc 1000 DC
Protection level	Up 1,800 DC	Up 2,000 DC	Up 2,500 DC	Up 3,000 DC
Nominal discharge impulsive current 8/20	under 20 kA	under 20 kA	under 20 kA	under 20 kA
Maximum discharge current 8/20	I _{max} 40 kA	I _{max} 40 kA	I _{max} 40 kA	I _{max} 40 kA
Connection wire sections	4 ... 25 mm ²	4 ... 25 mm ²	4 ... 25 mm ²	4 ... 25 mm ²
Reaction time	t _a < 25 nS	t _a < 25 nS	t _a < 25 nS	t _a < 25 nS
Working temperature	-40°C < T < 80°C	-40°C < T < 80°C	-40°C < T < 80°C	-40°C < T < 80°C
Failure indicator	Green OK/Red FAILURE	Green OK/Red FAILURE	Green OK/Red FAILURE	Green OK/Red FAILURE
Remote failure signal	Contact SPDT 1 A/230 AC*	Contact SPDT 1 A/230 AC*	Contact SPDT 1 A/230 AC*	Contact SPDT 1 A/230 AC*
Remote signal connections	Extractable clamps 1.5 mm ² - 6 A - 120 V	Extractable clamps 1.5 mm ² - 6 A - 120 V	Extractable clamps 1.5 mm ² - 6 A - 120 V	Extractable clamps 1.5 mm ² - 6 A - 120 V
Assembly	On omega TH35 guide	On omega TH35 guide	On omega TH35 guide	On omega TH35 guide
Case material	Self-extinguishing UL94V0	Self-extinguishing UL94V0	Self-extinguishing UL94V0	Self-extinguishing UL94V0
Degree of protection	IP20	IP20	IP20	IP20
Colour	Yellow	Yellow	Yellow	Yellow
Price per package	1	1	1	1
Dimensions (LxHxD) mm	52.5x81x68	52.5x81x68	52.5x81x68	52.5x81x68

* NOTE: When discharge is efficient, the 11 - 14 contact is closed; when the discharge device is broken down or removed, the 11 - 14 contact opens and closes the 11 - 12 contact.

Surge Protection Devices under alternate current

Surge protection devices (SPDs) are: devices that impede transitory power surges, conducted through the power supply network through the earthing network or signal network, from damaging the electronic command and control systems as well as protecting electronic devices in general. The BY7 series SPDs limit dangerous surges to levels accepted under regulations and that are tolerated by the devices

Where and how they should be used

In accordance with the regulations in effect, the BY7 power surge protective devices must be installed on the incoming power supply lines for the electric distribution and control panels and the automation command panels, to guarantee that the devices contained within are immune to surges, including PLC, industrial PCs, power supplies, inverters, etc. Conformance to EMC Regulations for command and control panels, generally in Surge Category II according to IEC-EN 644-1, requires that the maximum power surges applied to

recommended for use in Surge Category II or greater (surge max 2.5kV), in surge protection zone B and C (Zone 1 and 2), if the system does not have a lightning rod, in protection zone C (Zone 2) if the system has a lightning rod, and are considered Test Class II SPDs as required under the IEC1024, IEC1312-1, and EN50083-1 regulations in effect.

the devices be less than 2.5kV, which is also required under EN61000-4-4, 4-5. If the command and control panels do not have SPDs with residual surges less than the 2.5kV that the devices are able to support installed, then in the case of surges it is possible that malfunctions will occur and the system or machine will stop operating, leading to costs much higher than that of the SPDs. Additionally, installation of SPDs is required for conformance with the EMC regulations and to have the CE mark on the cabinet.

Performance of ISPD1455x BY7-40/3 series SPDs

These consist of a wiring base which can be assembled on a DIN guide and an extractable protection cartridge which contains the discharge device, which makes it easy to disconnect the SPD during insulation tests or for quick replacement when useful life has ended. BY7 series SPDs are able to support 10 surges of I_{sc} 20kA discharge current with 8/20 impulse and a single surge of 40kA, which statistically is very rare.

As required by the product regulations for SPDs, the BY7

series is provided with an internal thermal auto-disconnection device able to disconnect the line converter in the case of malfunctioning, providing an indication of the malfunctioning discharge device visible on the front of the unit and through a clean contact. When an SPD has reached the end of its useful life, after several surges and years of service, it can be quickly replaced by extracting it from the base and replacing it with the same model without disconnecting the power supply.

Protective devices and fuses

BY7 series SPDs include a device that disconnects varistors at the end of their useful life (nearing short circuit or in short circuit). Nonetheless, they also must be provided with protection against short-circuit currents inserted upstream and a protection differential against indirect contact (generally

already done at installation). BY7 should not be installed downstream from high-sensitivity protection differential devices.

Surge Protection Devices

Connections to main electrical networks

BY7 series SPDs can be used for the following types of connections:

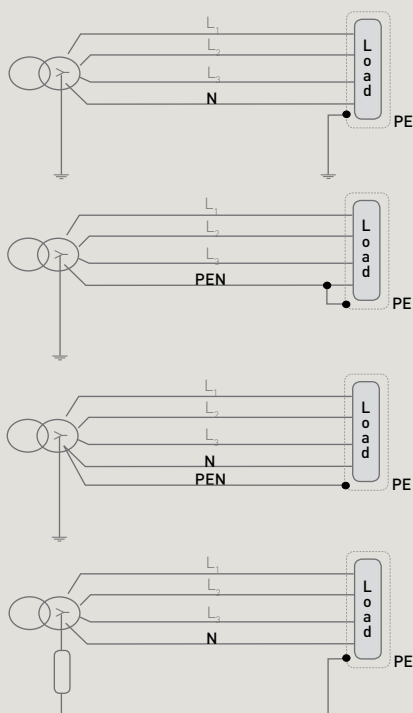
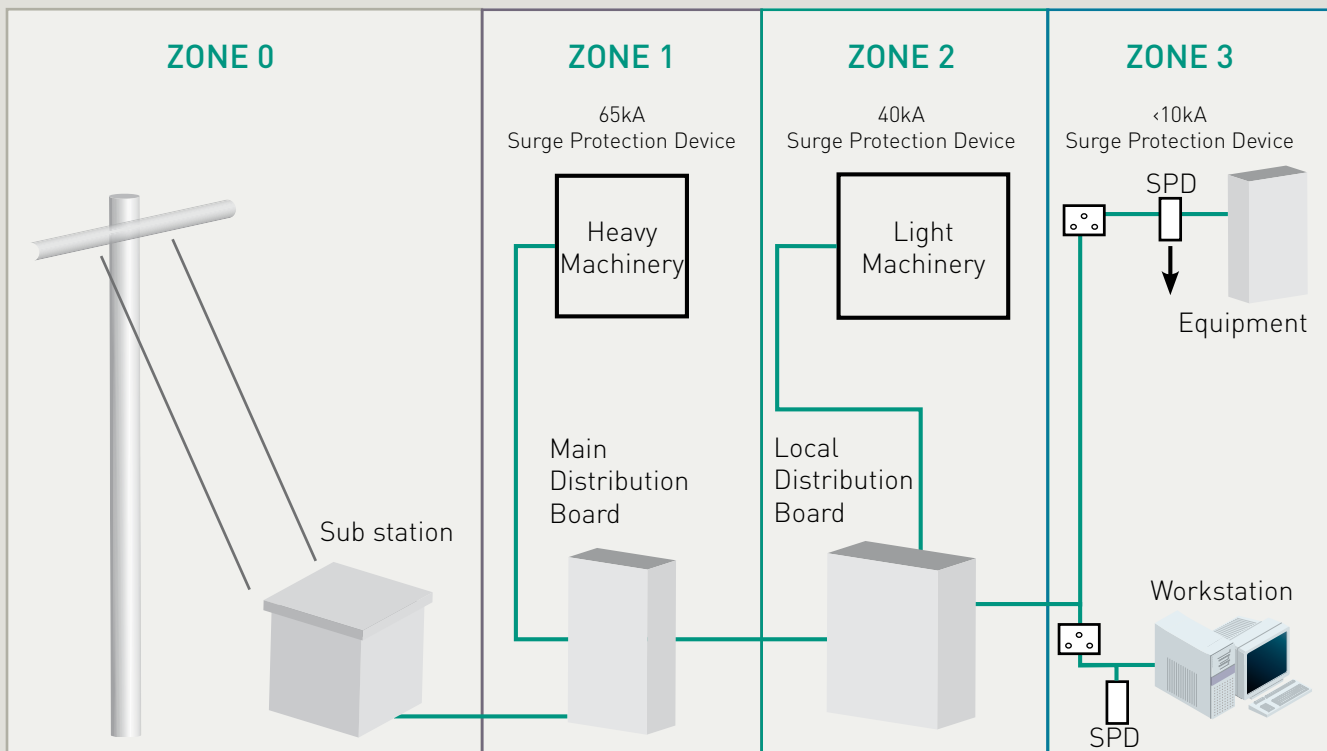

E - E type Earth system (Earth - Earth)

The neutral is earthed in the room. The devices and system are connected to an earth that may be either neutral or another earthed point.

E - NC type Earth system (Earth - Neutral Common)

In this system, the neutral of the transformer is directly connected to the earth. Neutral and earth are connected by a single PEN connection.

E - NS type Earth system (Earth - Neutral Separated)

In this system, the neutral of the transformer is directly connected to the earth. Neutral and earth are two separate lines.

Type of earth system: IT

In this system, the neutral is not connected to the earth and hence has high impedance. Generally, these are the user's earths.

Modular Surge Protection Devices under alternate current

The Surge Protection Devices are suitable for protecting the system against excess voltage induced by atmospheric discharge (lightening). The SPD under AC are inserted downstream of the inverter, in the photovoltaic sheets. Models with voltages from 230 to 400 AC are available with varistor technology (MOV - Metal Oxide Varistor) and to

discharge gas (GDT - Gas Discharge Tube) in individual modules, which can be composed according to need and system type.

The technical features of each model are given in the table below.



Code	ISPD14275	ISPD1425G	ISPD14440	ISPD1444G
ID number	BY7-40/1-275	BY7-NPE/40-275	BY7-40/1-440	BY7-NPE/40-440
Use category	II	II	II	II
Earth system	TN-S; TN-C; TT; IT	TN-S; TN-C; TT; IT	TN-S; TN-C; TT; IT	TN-S; TN-C; TT; IT
Technology	MOV (Metal Oxide Varistor)	GDT (Gas Discharge Tube)	MOV (Metal Oxide Varistor)	GDT (Gas Discharge Tube)
Nominal voltage	Un 230 AC	Un 230 AC	Un 400 AC	Un 400 AC
Maximum direct voltage	Uc 275 AC	Uc 255 AC	Uc 440 AC	Uc 440 AC
Protection level	Up ≤ 1,200 V	Up ≤ 1,800 V	Up ≤ 2,000 V	Up ≤ 1,800 V
Nominal discharge impulsive current 8/20	under 20 kA	under 30 kA	under 20 kA	under 30 kA
Maximum discharge current 8/20	I _{max} 40 kA	I _{max} 40 kA	I _{max} 40 kA	I _{max} 40 kA
Connection wire sections	4 ... 25 mm ²	4 ... 25 mm ²	4 ... 25 mm ²	4 ... 25 mm ²
Reaction time	t _a < 25 nS	t _a < 25 nS	t _a < 25 nS	t _a < 25 nS
Working temperature	-40°C < T < 80°C	-40°C < T < 80°C	-40°C < T < 80°C	-40°C < T < 80°C
Failure indicator	Green OK/Red FAILURE	No	Green OK/Red FAILURE	No
Remote failure signal	Contact SPDT 1 A/230 AC*	No	Contact SPDT 1 A/230 AC*	No
Remote signal connections	Extractable clamps 1.5 mm ² - 6 A - 120 V	No	Extractable clamps 1.5 mm ² - 6 A - 120 V	No
Assembly	On omega TH35 guide	On omega TH35 guide	On omega TH35 guide	On omega TH35 guide
Case material	Self-extinguishing UL94V0	Self-extinguishing UL94V0	Self-extinguishing UL94V0	Self-extinguishing UL94V0
Degree of protection	IP20	IP20	IP20	IP20
Colour	Yellow	Yellow/Blue	Yellow	Yellow/Blue
Price per package	1	1	1	1
Parallel bridges	2 poles	9000392 [BP2]	9000392 [BP2]	9000392 [BP2]
	3 poles	9000393 [BP3]	9000393 [BP3]	9000393 [BP3]
	4 poles	9000394 [BP4]	9000394 [BP4]	9000394 [BP4]
Dimensions [LxHxD] mm	17.5x81x68	17.5x81x68	17.5x81x68	17.5x81x68

* NOTE: When discharge is efficient, the 11 - 14 contact is closed; when the discharge device is broken down or removed, the 11 - 14 contact opens and closes the 11 - 12 contact.

Components for String Boxes

Accessories and spare parts

Cabur offers a range of accessories and spare parts for its own String Boxes and components for the customer to construct his/her own panels.

The raNge, which includes a selector of articles which comply with the quality standards and the most common market needs, is composed of:

■ Boxes for distribution panels and relative accessories for

assembly

- Clamps with screws
- Diodes
- Fuse holders and fuses
- Disconnectors
- Distribution terminal board

Boxes for distribution panels

Resistant to atmospheric agents

For the construction of customised panels, 4 box models in polycarbonate are available, with insulation class 2, IP66, resistant to UV rays and to corrosion caused by environmental agents.

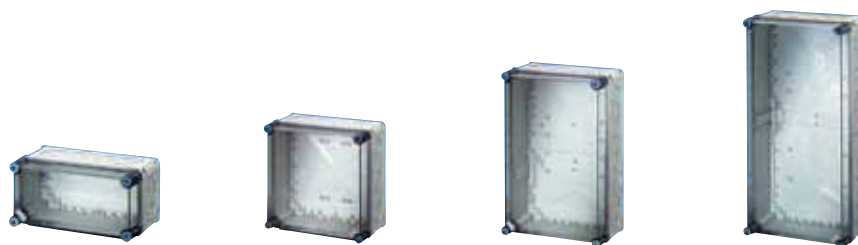

Box

Code	9000417	9000418	9000419	90004120
ID number	MI0100	MI0200	MI0300	MI0400
Height (mm)	150	300	450	600
Width (mm)	300	300	300	300
Depth (mm)	180	180	180	180

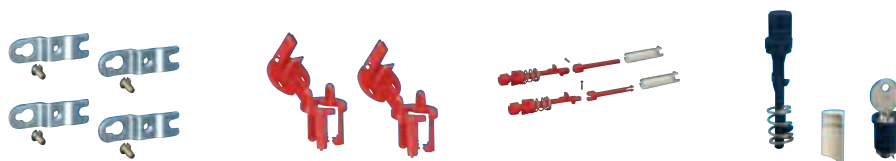

Accessories

Code	9000430	9000432	9000431	9000434
ID number	MIAL40	MIZS20	MIPL2	MIZS11
Description	External bracket to fix box	Cover hinge	Closure caps which can be lead sealed	Key closure
Q.ty per package	4	2	2	1

Boxes for distribution panels

Positioning for MIZS20 hinges

Box model		MI0100	MI0200	MI0300	MI0400
Box in vertical position	Left	Yes	Yes	Yes	Yes
	Right	Yes	Yes	Yes	Yes
	Above	Yes	Yes	Yes	Yes
	Below	Yes	Yes	No	No
Box in horizontal position	Left	Yes	Yes	No	No
	Right	Yes	Yes	No	No
	Above	Yes	Yes	Yes	Yes
	Below	Yes	Yes	Yes	Yes

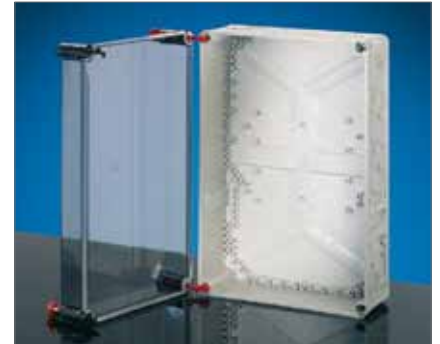

Example of positioning of MIAL40 bracket

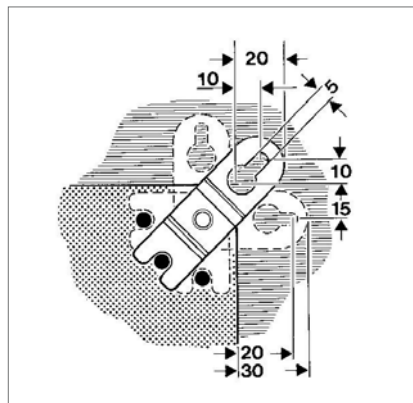
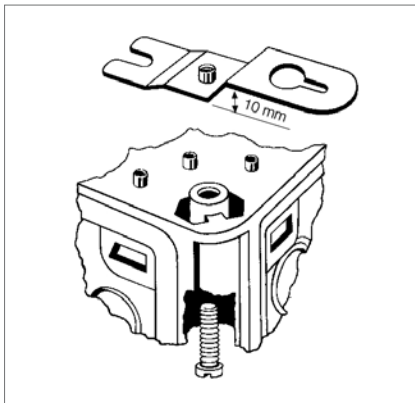

Technical features

- Material: high quality polycarbonate
- Shock resistance IK 8 (equal to 5 Joules) according to DIN 50102
- Without halogen gas
- Without silicones
- Resistant to aggressive chemicals, acids, benzenes and mineral oils (10% acid, 10% alkaline)
- Insulation class 2
- Resistant to temperatures from - 40 to + 120°C.
- Working temperature from - 25 to +45°C.
- Humidity 50% at 40°C, 100% at 25°C.
- IP 66 protection degree
- Maximum current: 630 A. according to IEC 60 439.1
- Resistant to UV rays, tested and certified for installation in direct sunlight
- Resistant to corrosion cause by weather such as rain, ice, and snow
- Tested with incandescent wire at 960°C. according to IEC 60 695 - 2 - 11
- Self-extinguishing
- With 3 smooth walls and one perforated
- With transparent cover
- Available already accessories for lead sealed closure

Screw-clamp terminal blocks

1000DC nominal voltage

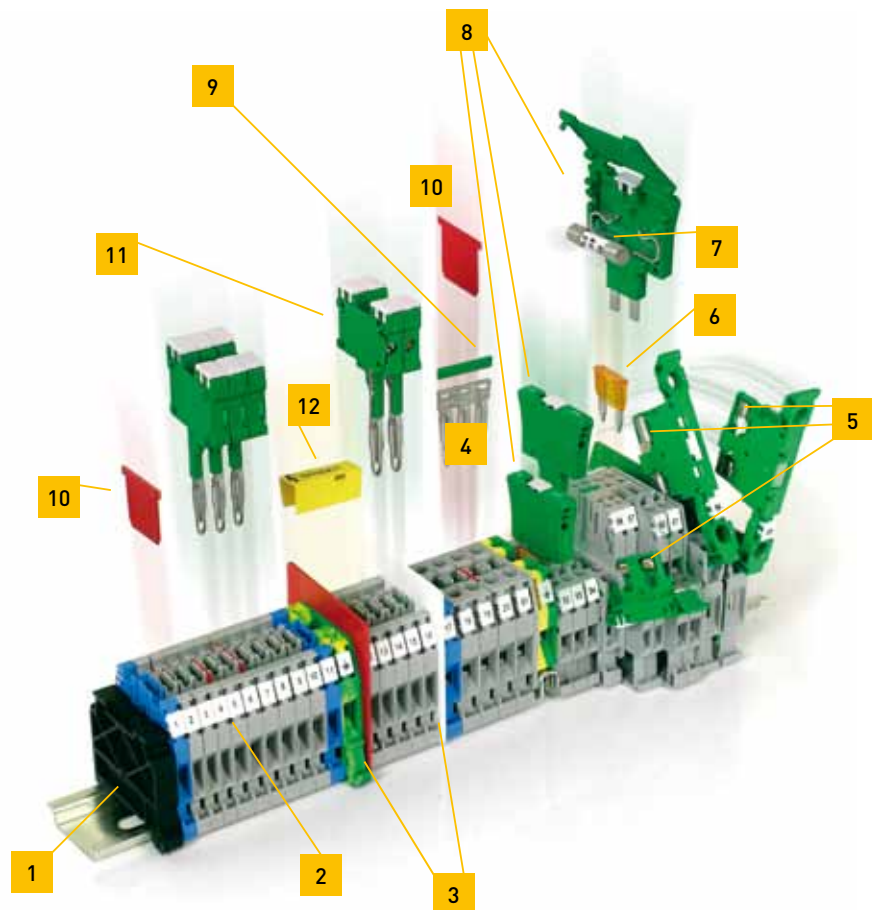

Series CBC terminal board
and relative Accessories

- 1 - End bracket
- 2 - ID Number
- 3 - Cross connection barrier
- 4 - PTC Easy Bridge parallel bridge
- 5 - Conductor element
- 6 - Blade fuse*
- 7 - 5x20 Fuse*
- 8 - CPF/5 Item holder cartridge (fuse/resistance/diode)*
- 9 - Bridge identification strip
- 10 - Cross connection barrier
- 11 - Modular test plugs
- 12 - Injury protection label

* Accessories not suitable for PV applications. For suitable fuses please see page 58.

To construct the connections of photovoltaic wires with a section larger than 6 mm², we recommend, inside of the terminal boxes and/or electrical panels, our CBC series terminal blocks (for wires with sections between 4 and 35 mm²), CBD series (for wires with sections between 50 and 240 mm²), GPA serie (for wires with sections between 50 and 240 mm²) and GPM series. These terminal block families are particularly suitable for photovoltaic environments both for

their well known technical-qualitative features which have made them famous in various other application fields, and above all because they can be used under direct current up to 1000V. To connect the strings, Line 3 and 4 photovoltaic connectors are recommended, while for connections with high current the terminal blocks found on the following pages are recommended.

Screw-clamp terminal blocks

1000DC nominal voltage



CBC series

Code	CBC02GR	CBC04GR	CBC06GR	CBC10GR	CBC16GR	CBC35GR	
ID number	CBC.2/GR	CBC.4/GR	CBC.6/GR	CBC.10/GR	CBC.16/GR	CBC.35/GR	
For flexible/rigid conductors	from 0.2 to 4 mm ²	from 0.2 to 6 mm ²	from 0.2 to 10 mm ²	from 1.5 to 16 mm ²	from 1.5 to 25 mm ²	from 2.5 to 50 mm ²	
Nominal current according to CEI EN 60947-7-1	24 A	32 A	41 A	57 A	101 A [25 mm ²]	150 A [50 mm ²]	
Nominal voltage according to CEI 60947-7-1	1000 V	1000 V	1000 V	1000 V	1000 V	1000 V	
Height/ Width/ Thickness (mm)							
TH/35 7.5 mm	52/ 44/ 5	52/ 44/ 6	52/ 44/ 8	52/ 44/ 10	56/ 47/ 12	63/ 56/ 16	
TH/35 15 mm	60/ 44/ 6	60/ 44/ 6	60/ 44/ 8	60/ 44/ 10	64/ 47/ 12	71/ 56/ 16	
Earth terminal	Code	T0910	T0430	T0120	T0510	T0220	T0320
	ID num.	TE0.2	TE0.4	TEC.6/0	TEC.10/0	TEC.16/0	TEC.35/0



GPA Series Power Terminal Blocks

Code	GA400GR	GA100GR	GA200GR	GA300GR
ID number	GPA.70/GR	GPA.95/GR	GPA.150/GR	GPA.240/GR
For flexible/rigid conductors	from 10 to 95 mm ²	from 10 to 95 mm ² / from 10 to 120 mm ²	from 50 to 150 mm ² / from 50 to 185 mm ²	from 95 to 240 mm ² / from 50 to 300 mm ²
Nominal current according to CEI EN 60947-7-1	192 A	232 A	309 A	415 A
Nominal voltage according to CEI 60947-7-1	1000 V	1000 V	1000 V	1000 V
Height/ Width/ Thickness (mm)				
TH/35 7.5 mm	70/ 91/ 20.5	87/ 98/ 26	99/ 108/ 31	120/ 119/ 37
TH/35 15 mm	78/ 91/ 20.5	95/ 98/ 26	106/ 108/ 31	128/ 119/ 37
Earth terminal	Code	T0810	-	-
	ID num	TEC. 70/0	-	-

Screw-clamp terminal blocks



CBD Series

Code	CB240	CB340	CB440
ID number	CBD.4	CBD.6	CBD.10
For flexible/rigid conductors	from 0.5 to 6 mm ²	from 0.5 to 10 mm ²	from 0.5 to 16 mm ²
Nominal current according to CEI EN 60947-7-1	32 A	41 A	57 A
Nominal voltage according to CEI 60947-7-1	1000 V	1000 V	1000 V
Height/ Width/ Thickness (mm) TH/35 7.5 mm TH/35 15 mm	52/ 44/ 6.5 60/ 44/ 6.5	52/ 44/ 8 60/ 44/ 8	52/ 44/ 10 63/ 44/ 10



CBD Series

Code	CB510	CB610	CB710	CB810
ID number	CBD.16	CBD.35	CBD.50	CBD.70
For flexible/rigid conductors	from 0.5 to 25 mm ²	from 0.5 to 35 mm ²	from 1.5 to 50 mm ²	from 1.5 to 95 mm ²
Nominal current according to CEI EN 60947-7-1	76 A	125 A	150 A	192 A
Nominal voltage according to CEI 60947-7-1	1.000 V	1.000 V	1.000 V	1.000 V
Height/ Width/ Thickness (mm) TH/35 7.5 mm TH/35 15 mm	57/ 47/ 12 65/ 47/ 12	60/ 52/ 16 68/ 52/ 16	62/ 57/ 18 70/ 57/ 18	71/ 62/ 20.5 79/ 62/ 20.5

Screw-clamp terminal blocks

1000DC nominal voltage



GPM Series Power Terminal Blocks

Code	GP100	GP400	GP700	GP200
ID number	GPM.95/BB	GPM.150/BB	GPM.240/BB	GPM.95/BC
For flexible/rigid conductors	-	-	-	from 35 to 120 mm ² / from 25 to 120 mm ²
Nominal current according to CEI EN 60947-7-1	69 A	353 A	452 A	69 A
Nominal voltage according to CEI 60947-7-1	1000 V	1000 V	1000 V	1000 V
Height/ Width/ Thickness (mm)				
TH/35 7.5 mm	81/ 176/ 32	81/ 200/ 42	89/ 250/ 52	81/ 176/ 32
TH/35 15 mm	88/ 176/ 32	88/ 200/ 42	96/ 250/ 52	88/ 176/ 32
Version for anchoring to the panel				
Code	GP110	GP410	GP710	GP210
ID number	GPM.95/BB/FIX	GPM.150/BB/FIX	GPM.240/BB/FIX	GPM.95/BC/FIX



Code	GP500	GP800	GP300	GP600	GP900
ID number	GPM.150/BC	GPM.240/BC	GPM.95/CC	GPM.150/CC	GPM.240/CC
For flexible/rigid conductors	from 50 to 185 mm ² / from 35 to 185 mm ²	from 95 to 300 mm ²	from 35 to 120 mm ² / from 25 to 120 mm ²	from 50 to 185 mm ² / from 35 to 185 mm ²	from 95 to 300 mm ²
Nominal current according to CEI EN 60947-7-1	353 A	452 A	69 A	353 A	452 A
Nominal voltage according to CEI 60947-7-1	1000 V	1000 V	1000 V	1000 V	1000 V
Height/ Width/ Thickness (mm)					
TH/35 7.5 mm	81/ 200/ 42	89/ 250/ 52	81/ 176/ 32	81/ 200/ 42	89/ 250/ 52
TH/35 15 mm	88/ 200/ 42	96/ 250/ 52	88/ 176/ 32	88/ 200/ 42	96/ 250/ 52
Version for anchoring to the panel					
Code	GP510	GP810	GP310	GP610	GP910
ID number	GPM.150/BC/FIX	GPM.240/BC/FIX	GPM.95/CC/FIX	GPM.150/CC/FIX	GPM.240/CC/FIX

Disconnectors

For photovoltaic applications

The offer is for 2 disconnectors:

- conforming to standard EN 60947-3 with reference to VDE 0660 Part 107
- Use category: DC-21A for photovoltaic applications
- working temperature: 50°C (max. 55°C for short periods)

- finger-proof IP20 disconnector in accordance with VDE 0660-514
- external manoeuvre

The size and structure of the disconnectors are optimised for use with Cabur boxes

NOTE: The disconnectors proposed are for external manoeuvring; however the photos refer to switches with internal manoeuvring, which are not available.

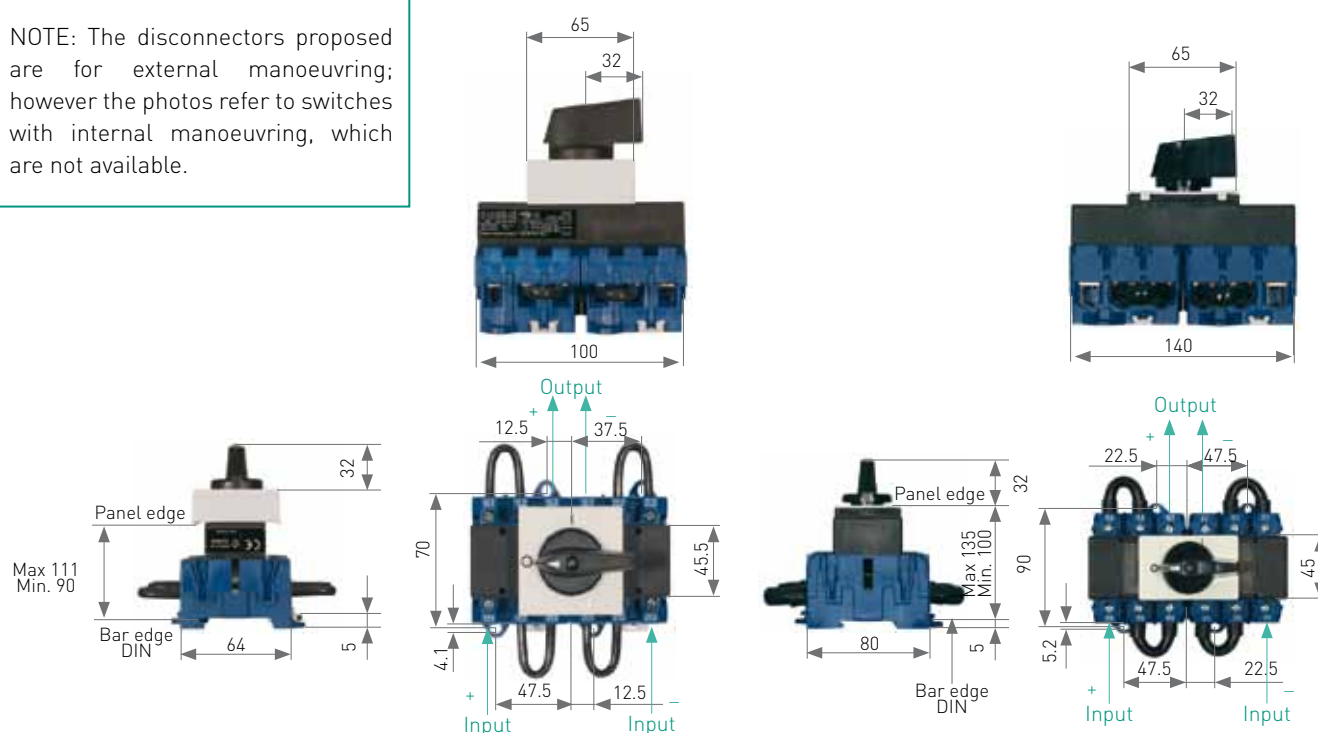

Code	9000373	9000374
ID number	KG41B	KG80
Connection Diagram		
Tape length	10	14
Current and Nominal voltage	DC-21A: 40 A 690 DC DC-22A: 32 A 650 DC	DC-21A: 80 A 690 DC DC-22A: 63 A 650 DC
Max Voltage Cut-Off	690 V DC	690 V DC
Insulation voltage	1000 V	1000 V
Max wire section: - Standard wire - Flexible wire	16 mm ² 10 mm ²	50 mm ² 35 mm ²
Stripping length	10 mm	14 mm
Tightening torque	180 Nm	300 Nm
Assembly	On IEC 60715/TH35 guidelines and on panels by means of anchorage screws	On IEC 60715/TH35 guidelines and on panels by means of anchorage screws
Quantity / Packaging	1	1

QBLOK terminal boards

Distribution terminal boards

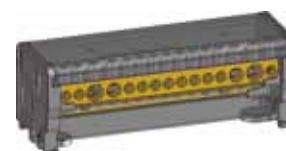

NOTE: The images are of prototypes.

Code	QBLOK2100	QBLOK2125	QBLOK2126
ID number	QBLOK2P100A7	QBLOK2P125A11	QBLOK2P125A15
Description	Terminal board with 2 holes \varnothing 7.5 mm + 5 holes \varnothing 5.4 mm	Terminal board with 2 holes \varnothing 9 mm + 2 holes \varnothing 7.5 mm + 7 holes \varnothing 5.4 mm	Terminal board with 2 holes \varnothing 9 mm + 2 holes \varnothing 7.5 mm + 11 holes \varnothing 5.4 mm
Height/ Width/ Thickness			
	TH/35 7.5 mm	52/49/72	52/49/109
	TH/35 15 mm	59/49/72	59/49/109
Use/Type	Bipolar distribution terminal board	Bipolar distribution terminal board	Bipolar distribution terminal board
Nominal section (mm ²)	25	35	35
Connection capacity (hole \varnothing 9 mm)			
Flexible conductors (mm ²)	-	10 ÷ 35	10 ÷ 35
Rigid conductors (mm ²)	-	10 ÷ 35	10 ÷ 35
Max flexible conductor with terminal (mm ²) terminal ID number	-	25 - WP250/29	25 - WP250/29
Connection capacity (hole \varnothing 7.5 mm)			
Flexible conductors (mm ²)	10 ÷ 25	10 ÷ 25	10 ÷ 25
Rigid conductors (mm ²)	10 ÷ 25	10 ÷ 25	10 ÷ 25
Max flexible conductor with terminal (mm ²) terminal ID number	16 - WP160/22	16 - WP160/22	16 - WP160/22
Connection capacity (hole \varnothing 5.4 mm)			
Flexible conductors (mm ²)	2.5 ÷ 6	2.5 ÷ 6	2.5 ÷ 6
Rigid conductors (mm ²)	2.5 ÷ 6	2.5 ÷ 6	2.5 ÷ 6
Max flexible conductor with terminal (mm ²) terminal ID number	4 - WP40/16	4 - WP40/16	4 - WP40/16
Nom. voltage/Nom. current/Calibre	1000V/100A/- sec. EN 60947-1	1000V/125A/- sec. EN 60947-1	1000V/125A/- sec. EN 60947-1
Short term current allowed (low)	3 kA (effective for 1s) according to EN 60947-7-1	4.2 kA (effective for 1s) according to EN 60947-7-1	4.2 kA (effective for 1s) according to EN 60947-7-1
Surge voltage measurement/Degree of pollution	8 kV/3	8 kV/3	8 kV/3
Stripping length (mm)	13	13	13
Test/Recommended Tightening torque	1.8/2.2 Nm	1.8/2.2 Nm	1.8/2.2 Nm
Certifications	IMQ	IMQ	IMQ

NOTE: Available in February 2011

IMQ certification pending

QBLOK terminal boards

Accessories

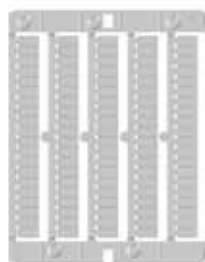
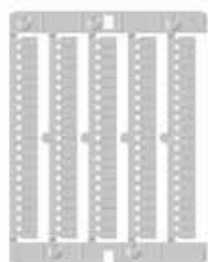

Code	NU0851	NU1051	BT005
ID number	CNU/8/51/...	CNU/10/51/...	BTU for PR/DIN and PR/3
Description	ID label (numbered or neutral)	ID label (numbered or neutral)	End bracket



Code	BT003-BT007	PR003	PR005
ID number	BT/3-BT0 only for PR/3	PR/3/AC in steel	PR/3/AS same with slot
Description	End bracket	Support profile conforms to IEC 60715	Support profile conforms to IEC 60715

Technical characteristics of QBLOK terminal boards

- Mounting onto PR/3 profiles conforming to IEC 60715 standards TH/35 type or directly onto the panel
- Insulating supports made of 6.6 UL94V-0 polyamide and insulating cover of transparent polycarbonate
- Insulating screen for each conducting bar
- Power supply holes intentionally offset for better conductor cabling
- Possible to label each bar with a CNU/8 or CNU/10 tag
- Conform to EN 60947-7-1
- Nominal Insulation voltage 1000 V - according to EN 60947-1 (effective value in AC or value in DC)
- Appropriate for photovoltaic systems

Fuse holders and fuses

For string protection

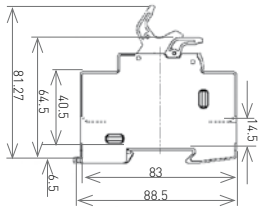

Fuse holders for fuses of 10.3 x 38 mm

- For use with rigid wires from 1 to 16 mm², (18-6 AWG) or with multistrand wires from 0.75 to 10 mm² (18-8AWG)
- Maximum tightening torque: 2.5 Nm (22lb-in)
- IR for fuses: 120KA @ 500V IEC – 80KA @ 690V IEC – 80KA @ 700V UL

Code	9000375
ID number	US101
Nominal voltage	800 AC 1000 DC
Insulation voltage	6 kV
Nominal current	30 A
Max dissipated power	3 W
Nominal current of fuses	1 ... 30 A
Assembly	On omega TH35 guide
Pieces per pack	12

Fuses of 10.3 x 38 mm

- Nominal voltage: 750 AC – 1000 DC
- Interruption power 100kA
- Approved UL-FILE E60314
- Conforming with ROHS and REACH



Code	9000401	9000402	9000403	9000404	9000405	9000406	9000407
ID number	DCT1-2	DCT2-2	DCT3-2	DCT4-2	DCT5-2	DCT6-2	DCT7-2
Nominal current	1 A	2 A	3 A	4 A	5 A	6 A	7 A
Quantity / Packaging	10	10	10	10	10	10	10

Code	9000408	9000409	9000410	9000411	9000412	9000413	9000414
ID number	DCT8-2	DCT10-2	DCT12-2	DCT15-2	DCT20-2	DCT25-2	DCT30-2
Nominal current	8 A	10 A	12 A	15 A	20 A	25 A	30 A
Quantity / Packaging	10	10	10	10	10	10	10

Diodes

For strings of photovoltaic panels

Designed to facilitate photovoltaic system designers and installers in fitting the diode on the solar panels. The coupling for DIN guide makes installation fast and safe.

Working voltage allows for use of systems according to standard 60364-7-712.



Code	ISDS102	9000395	SF903GR
ID number	KXDS102	T20HF220	SFR.4/D3A/GR
Description	Diode for PV strings	Diode for PV strings	Sectionable diode holder
Voltage of insulation towards the DIN guide	3.75 kACa/ 5 sec.	5 kAC/ 60 sec.	3 kAC/ 60 sec.
Max Inverse Voltage	2 kV	22 kV	13 kV
Max. String Voltage	1000 V	1.1 kV	650 V
Nominal current	10 A @ 25°C	12 A @ 45°C	3 A @ 25°C
Max working voltage	15 A	250 A x 10 ms	20 A
Max working voltage	45° C	95° C	45° C
Dissipated power	16 W @ 10 A	10 W @ 7.5 A; 20 W to 17 A	3.3 W @ 3 A
Connections	Faston 6.3	Wire terminal clamp Ø 5 mm	4 mm screw-on terminal
Assembly	On omega TH35 guide	Screwed onto metallic panel (recommended thickness 3 mm) or dissipater	On omega TH35 guide
Weight	235 g	54 g	35 g
Dimensions (LxHxD) mm	24x77x80	24x41x25	8x52x52

Control terminal boards

UTF for measuring by manoeuvring TA and TV



Cabur control terminal boards are designed to allow electricity providers and users the possibility of easily checking on the measuring instruments, without interrupting current flow during control or during possible replacement of the instruments.

ENEL has adopted a special colour system to identify phases according to the geographic areas where the terminal boards will be installed.

Every terminal board is composed of an insulating base which holds the terminal blocks, in copper-zinc alloy, of the volt and amp meter circuits, and the devices for cut-off and short circuit operations. The base of the single phase terminal board is made of heat-hardened resin (black phenol resin). For the bi- and three-phase terminal boards, the insulating base is made of Kelon (Keramic + Nylon). This is a polymer with a nylon 6 base,

self-extinguishing UL94V-0, to which is added special ceramic spheres, after which it is thermally stabilized. The inclusion of the microspheres and the thermal procedure render the final product extremely resilient - rigid but still able to resist shocks and wear.

Every terminal board has a transparent cover (in cellulose acetate), provided with special screws that cannot be lost, by which the whole can be sealed.

Every screw has a special hole for the passage of the lead-sealing wire for UTF.

The phases are indicated in different colours, to be specified when ordering. The terminal boards should be positioned upstream of the two-direction meter or, as in the CEI 82-25 electrical diagrams, between meter and delivery point.

Technical characteristics

- Nominal section: 6 mm²
- Connection capacity:
 - flexible conductors: 0,5 ÷ 6 mm²
 - rigid conductors: 0,5 ÷ 6 mm²
- Conductor entry hole: ø 4,1 (mm)
- Tightening torque: 1,2 (Nm)
- Nom. current (sec. IEC 60947-7-1): 57 A
- Nom. voltage (sec. IEC 60947-7-1): 500 V
- Surge voltage resistance/degree of damage: 6 KV/3

Control terminal boards

MCM Series

With the MCM series terminal boards, the following can be done:

- cut-off, both up and down stream, of measurement tools
- insertion of a sample device, either before or after the measurement device
- derivation, through the use of shared plugs, of the four connection terminal blocks
- passage of voltage from the entry of the amp meter circuit to the knife, through a bridge that should be installed beforehand.

During normal operations, the volt meter power supplies are inserted onto the R-S-T terminal blocks, while the amp meter ones are inserted onto the terminal blocks labelled R1-R2, S1-S2, and T1-T2. The instruments are then connected to terminal blocks 1 and 2. The vertical cursor connections are closed, while the horizontal cursor ones are open.

In the case that control devices are inserted, the process is as follows:

- using normal pins, the volt meter power supplies of the sample device are derived to the voltage plugs of the disconnecting knives or the fuse holder connection blocks;
- the amp meter power supplies of the control device are inserted to plugs 1 and R1 or to 2 and R2 and, similarly, to the other phases;
- then, the corresponding vertical cursor is disconnected.

In the case that measurement tools are replaced, it is necessary to first close the horizontal cursors, disconnect the vertical cursors, and open the knives. Entry and exit of the power supplies takes place at the rear part of the terminal board (rear panel entry), with conductors that are fed through holes made in the insulating base of the terminal boards themselves.

For contacts with single phase insertion

MCM.1



Maximum volume (with cover inserted):
95 x 85 x 48 mm

First drawing:
APPLICATION DIAGRAM

Second drawing:
FIXING TEMPLATE

ENEL has adopted a special colour system to identify phases according to the compartments where the terminal boards will be installed. Starting from the left, the phases are identified as follows:

Code	MCM.1/B	MCM.1/G	MCM.1/R
ID number	MC201B	MC201G	MC201R
Colour	White	Yellow	Red
Region	Campania and Lombardy	Veneto and Trentino Alto Adige	Rest of Italy

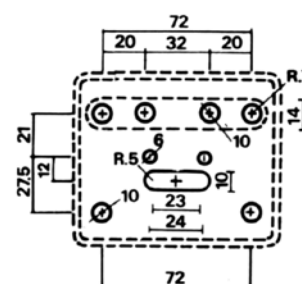
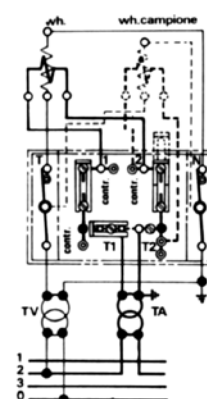

For contacts with ARON insertion

MCM.2

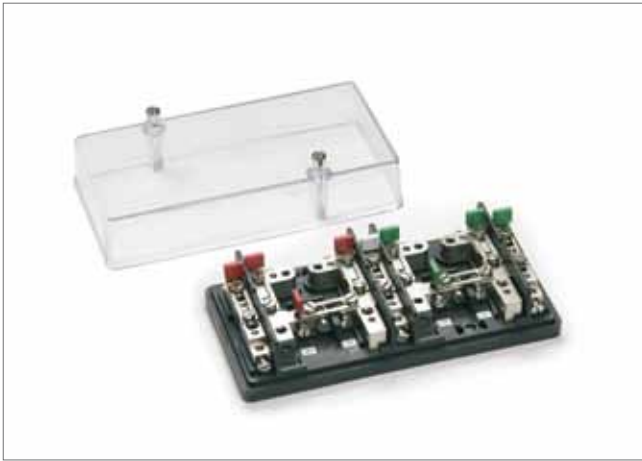

Maximum volume (with cover inserted):
170 x 85 x 48 mm

First drawing:
APPLICATION DIAGRAM

Second drawing:
FIXING TEMPLATE

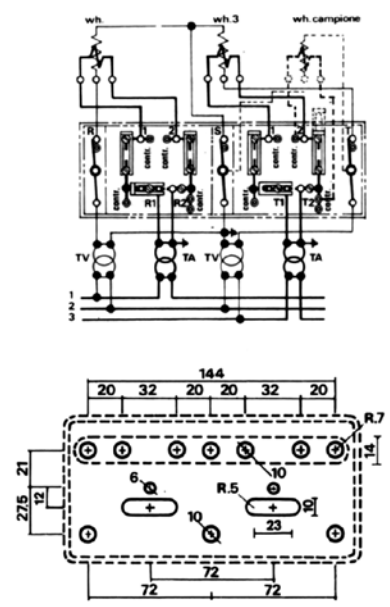

ENEL has adopted a special colour system to identify phases according to the compartments where the terminal boards will be installed. Starting from the left, the phases are identified as follows:

Code	MCM.2/B	MCM.2/G	MCM.2/R
ID number	MC202B	MC202G	MC202R
Colour	White	Yellow	Red
Region	Campania and Lombardy	Veneto and Trentino Alto Adige	Rest of Italy

For contacts with three phase and neutral insertion

MCM.3

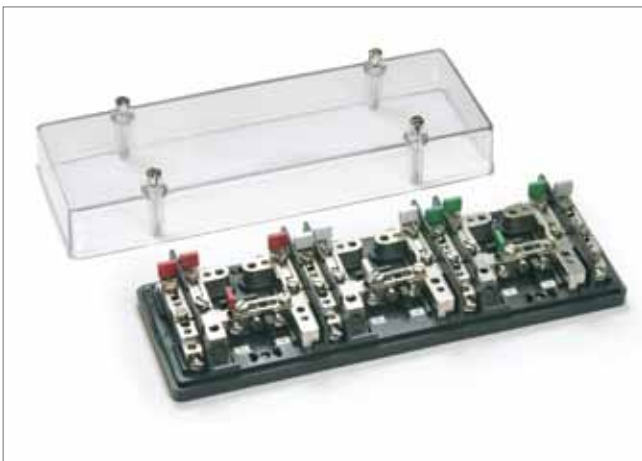

Maximum volume (with cover inserted):
95 x 85 x 48 mm

First drawing:
APPLICATION DIAGRAM

Second drawing:
FIXING TEMPLATE

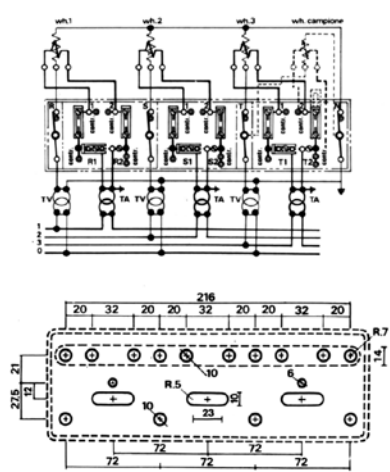

ENEL has adopted a special colour system to identify phases according to the compartments where the terminal boards will be installed. Starting from the left, the phases are identified as follows:

Code	MCM.3/B	MCM.3/G	MCM.3/R
ID number	MC203B	MC203G	MC203R
Colour	White	Yellow	Red
Region	Campania and Lombardy	Veneto and Trentino Alto Adige	Rest of Italy

For contacts with three phase and neutral insertion

MCM.3/VE

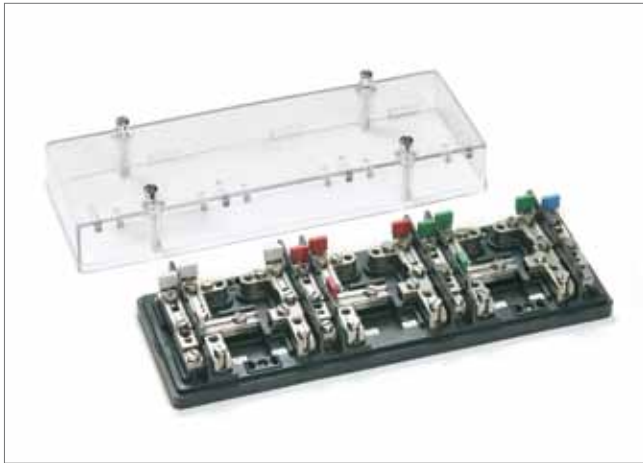

Maximum volume
(with cover inserted):
245 x 85 x 48 mm

First drawing:
APPLICATION
DIAGRAM

Second drawing:
FIXING TEMPLATE

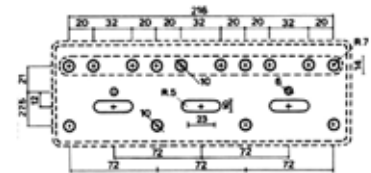
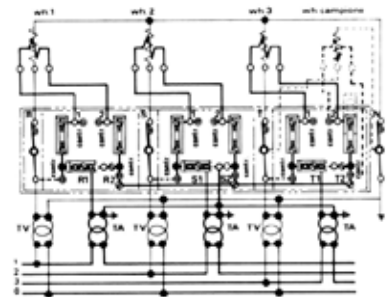

ENEL has adopted a special colour system to identify phases according to the compartments where the terminal boards will be installed. Starting from the left, the phases are identified as follows:

Code	MCM.3/VE/B	MCM.3/VE/G	MCM.3/VE/R
ID number	MC233B	MC233G	MC233R
Colour	White	Yellow	Red
Region	Campania and Lombardy	Veneto and Trentino Alto Adige	Rest of Italy

Control terminal board

MCT/SA Series

The series MCT/SA differs from the MCM series in the following ways:

- disconnection of voltages is done through the use of cursors, rather than knives
- both entry and exit of power supplies takes place at the front of the terminal board, with conductors that pass through open slots created on the upper and lower walls of the cover
- there is a door cover on the safety blocks which prevents them from closing when the cursors are not in the proper position. Methods of use for MCT/SA terminal boards are the same as those for the MCM series.

For contacts with single phase insertion

MCT.1/SA



Maximum volume
(with cover inserted):

95 x 85 x 48 mm

First drawing:
APPLICATION
DIAGRAM

Second drawing:
FIXING TEMPLATE

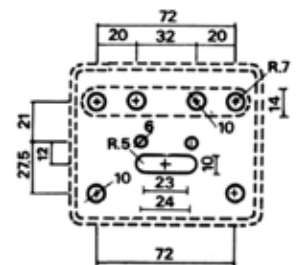
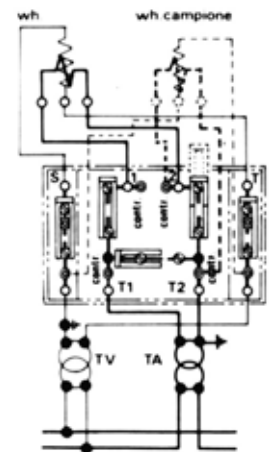

ENEL has adopted a special colour system to identify phases according to the compartments where the terminal boards will be installed. Starting from the left, the phases are identified as follows:

Code	MCT.1/SA/B	MCT.1/SA/G	MCT.1/SA/R
ID number	MC401B	MC401G	MC401R
Colour	White	Yellow	Red
Region	Campania and Lombardy	Veneto and Trentino Alto Adige	Rest of Italy

For contacts with ARON insertion

MCT.2/SA



Maximum volume (with cover inserted):
170 x 85 x 48 mm

First drawing:
APPLICATION DIAGRAM

Second drawing:
FIXING TEMPLATE

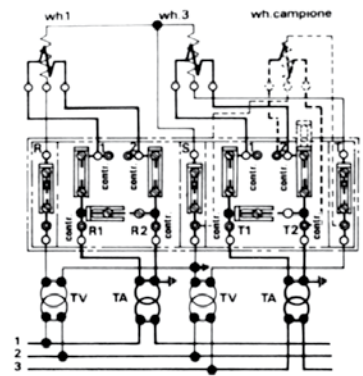

ENEL has adopted a special colour system to identify phases according to the compartments where the terminal boards will be installed. Starting from the left, the phases are identified as follows:

Code	MCT.2/SA/B	MCT.2/SA/G	MCT.2/SA/R
ID number	MC402B	MC402G	MC402R
Colour	White	Yellow	Red
Region	Campania and Lombardy	Veneto and Trentino Alto Adige	Rest of Italy

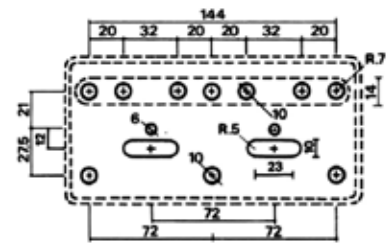

For contacts with three phase and neutral insertion

MCT.3/SA



Maximum volume (with cover inserted):
245 x 85 x 48 mm

First drawing:
APPLICATION DIAGRAM

Second drawing:
FIXING TEMPLATE

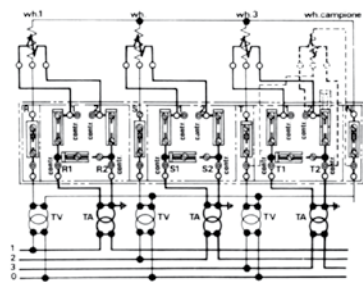

ENEL has adopted a special colour system to identify phases according to the compartments where the terminal boards will be installed. Starting from the left, the phases are identified as follows:

Code	MCT.3/SA/B	MCT.3/SA/G	MCT.3/SA/R
ID number	MC403B	MC403G	MC403R
Colour	White	Yellow	Red
Region	Campania and Lombardy	Veneto and Trentino Alto Adige	Rest of Italy

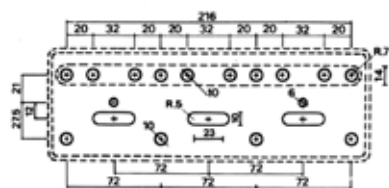

Joins in cast resin

For connecting wires with large sections

General features

- High mechanical rigidity
- High insulating power
- Working voltage 0.6 - 1 kV

Materials used

- Transparent polycarbonate
- Two-component epoxy resin

Conforming to standards

- CEI 20 - 33
- CEI 20 - 63
- Degree of protection: IP 68

Two-component epoxy resin for low voltage insulation Resistance to humidity, high insulating power, hardens at environmental temperature allowing for restoration and/or activation of the electrical system.

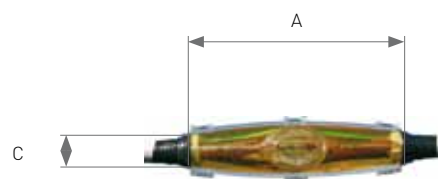

CGI

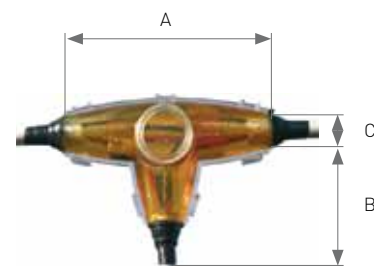

CGT



CGY

Code	ID number	Wire section (mm ²)										Dimensions (mm)			Diameter (mm)	
		1 x		2 x		3 x		4 x		5 x		A	B	C	MIN (mm)	MAX (mm)
		Main.	Deriv.	Main.	Deriv.	Main.	Deriv.	Main.	Deriv.	Main.	Deriv.					
CGI150	CGI/150LIN	1.5-35	-	1.5-6	-	1.5-4	-	1.6-6	-	1.5-2.5	-	150	39	34	7	15
CGI180	CGI/180LIN	1.5-150	-	1.5-25	-	1.5-16	-	1.5-16	-	1.5-10	-	173	58	49	7	25
CGI210	CGI/210LIN	6-240	-	1.5-50	-	1.5-35	-	1.5-35	-	1.5-25	-	211	71	60	10	31
CGI260	CGI/260LIN	35-185	-	4-35	-	2.5-35	-	2.5-25	-	1.5-16	-	264	59	53	15	29
CGI360	CGI/360LIN	70-400	-	10-500	-	10-70	-	10-50	-	6-50	-	360	77	68	20	39
CGY150	CGY/150DER	1.5-35	1.5-35	1.5-6	1.5-6	1.5-6	1.5-6	1.5-2.5	1.5-2.5	1.5-2.5	1.5-2.5	150	68	33	7	15
CGY180	CGY/180DER	1.5-150	1.5-150	1.5-6	1.5-6	1.5-6	1.5-6	1.5-6	1.5-6	1.5-2.5	1.5-2.5	183	81	44	7	15
CGY240	CGY/210DER	6-150	6-150	1.5-25	1.5-25	1.5-16	1.5-16	1.5-25	1.5-16	1.5-10	1.5-10	240	103	57	10	25
CGY310	CGY/360DER	70-400	16-185	10-50	1.5-50	10-95	1.5-35	6-70	1.5-35	6-50	1.5-16	310	132	78	20	30
CGT180	CGT/180DER	1.5-50	1.5-50	1.5-6	1.5-6	1.5-6	1.5-6	1.5-6	1.5-6	1.5-2.5	1.5-2.5	183	45	107	6	16
CGT240	CGT/240DER	6-150	6-150	1.5-25	1.5-25	1.5-6	1.5-16	1.5-16	1.5-16	1.5-10	1.5-10	246	56	143	10	25

Resin

Code	ID number	Weight
CGRES80	CGRES/80	80.0
CGRES210	CGRES/210	210.0
CGRES350	CGRES/350	350.0
CGRES450	CGRES/450	450.0

Before use, read the warnings and the instructions on the packaging carefully.

CGG junction boxes

For connecting wires with large sections

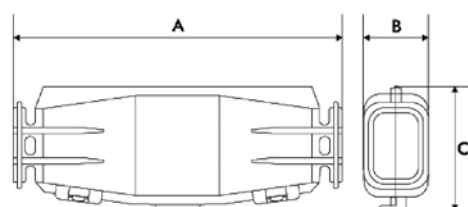

General features

- High sealant gel
- Working temperature: $- 20\text{ }^{\circ}\text{C} < T < + 90\text{ }^{\circ}\text{C}$
- High insulation power for voltages up to 1000V

Conforming to standards

CEI 20-33; CEI 20-63; CEI 64-8 (class II with double insulation)
CEI 70-1 (IP68 degree of protection)

Use

The CGG junction boxes in resin and polypropylene are mainly used for the junction of single-pole and multiple-pole extruded wires laid underground, submerged or overhead, and therefore for exposure to atmospheric agents such as water, dust, UV rays.

The absence of cast resin allows for successive inspection of the joint at any time after first installation and above all it allows for the addition of wiring modifications. The wires are enclosed between two very soft, insulating gelatinous surfaces which allow for repeated opening and closing of the box (when care must be taken to prevent dirt or extraneous bodies from entering).

Recommendations

Always make sure the wires are correctly crimped and that the electricity flow through the connection is not hindered; pull the ends of the wires to make sure of the mechanical resistance of the joint. Tighten bands around the main wire on the knurled part of the wire gland of the junctions box; this will prevent rotation of the wire inside the shell, thus also protecting the electrical joint from possible stress after wiring. Lastly, always check that the gel extends outside the junction box; if not, open the box and add a few pieces of sleeve left over from the previous wire stripping phase; this will increase the volume and the consequent overflow of the gel which ensures good insulation against atmospheric agents.

Code	ID number	Description	Colour	Straight joint	Derivative joint	V MAX	Package	A (mm)	B (mm)	C (mm)	
				Section of Entry and Exit (mm ²)	Section of Main line entry and exit (mm ²)	Wire section: Derivative line Exiting (mm ²)					
CGG30	CGG/30100	Junction box	Black	1x1.5 < Ø < 1x50	1x1.5 < Ø < 1x50	1x35 Ø 2x6	1000V	5	100	30	49
CGG50	CGG/50165	Junction box	Black	1x10 < Ø < 1x120 2x6 < Ø < 2x16 3x1 < Ø < 3x5 4x1.5 < Ø < 4x6	1x10 < Ø < 1x70 2x1.5 < Ø < 2x10 3x1.5 < Ø < 3x10 4x1.5 < Ø < 4x6	1 x 35 2 x 6 3 x 4 4 x 4	1000V	3	165	36	185
CGG100	CGG/100220	Junction box	Black	1x35 < Ø < 1x185 2x16 < Ø < 2x50 3x4 < Ø < 3x16 4x6 < Ø < 4x25	1x25 < Ø < 1x150 2x10 < Ø < 2x35 3x4 < Ø < 3x16 4x6 < Ø < 4x16	1 x 70 2 x 25 3 x 16 4 x 10	1000V	1	220	50	600

CODE	PAGE	CODE	PAGE
9000373	55	CBC06GR	52
9000374	55	CBC10GR	52
9000375	58	CBC16GR	52
9000392	48	CBC35GR	52
9000393	48	CGG100	67
9000394	48	CGG30	67
9000395	59	CGG50	67
9000401	58	CGI150	66
9000402	58	CGI180	66
9000403	58	CGI210	66
9000404	58	CGI260	66
9000405	58	CGI360	66
9000406	58	CGRES80	66
9000407	58	CGRES210	66
9000408	58	CGRES350	66
9000409	58	CGRES450	66
9000410	58	CGT180	66
9000411	58	CGT240	66
9000412	58	CGY150	66
9000413	58	CGY180	66
9000414	58	CGY240	66
9000417	49	CGY310	66
9000418	49	FG21M21	36.37
9000419	49	GA400GR	52
90004120	49	GA100GR	52
9000430	49	GA200GR	52
9000431	49	GA300GR	52
9000432	49	GP100	54
9000434	49	GP110	54
BT005	57	GP400	54
BT003-BT007	57	GP410	54
CB240	53	GP700	54
CB340	53	GP710	54
CB440	53	GP200	54
CB510	53	GP210	54
CB610	53	GP500	54
CB710	53	GP510	54
CB810	53	GP800	54
CBC02GR	52	GP810	54
CBC04GR	52	GP300	54

Code index

CODE	PAGE
GP310	54
GP600	54
GP610	54
GP900	54
GP910	54
IS0601207	23
IS0601209	23
IS0701206	17,18,20
IS0701207	17,18,19,20,21
IS0701208	17,18,20
IS0701209	17,18,19 20,21
IS101534611	29
IS101740277	29
IS13110	17
IS13112	17,35
IS13240	18
IS13242	18
IS14110	23.35
IS14240	16,23,25,35
IS15000	19,20,21,22,25
IS15001	19,20,21,22,25
IS15240	19,25,35
IS15242	19,25
IS15340	20
IS15341	20.25
IS15342	21
IS15BLOCK	24
IS15SBLOCK	24
IS201534611	29
IS201740277	29
IS211579002	31.35
IS23111	17
IS23113	17.35
IS23241	18
IS23243	18
IS24111	23.35
IS24241	16,23,25.35
IS25241	19,25,35
IS25243	19,25
IS25341	20

CODE	PAGE
IS25342	20,25
IS25343	21
IS261394461	27,35
IS301102855	31.35
IS301394461	27.30
IS301394462	27,30,35
IS301394738	28
IS3152	27,28,29.32 35
IS3153	13,14,17,18 19,20,21,32,35
IS3154	13,14,23,32,35
IS31579002	31.33
IS3161	13,31,34
IS3170	31.33
IS3170L	31
IS401394461	27.30
IS401394462	27,30,35
IS401394738	28
IS41310L	22
IS41310S	22.35
IS41410	23.35
IS42320L	22
IS42320S	22.35
IS42420	23.35
IS461394461	28
IS51400	14.24
IS52400	14.24
IS551394462	29.30
IS651394461	28.30
IS651394462	28.30
IS661394461	29.30
ISB01FXCA06	41
ISB01FXCA08	41
ISB01FXCA10	41
ISB01HXCA06	40
ISB01HXCA08	40
ISB01HXCA10	40
ISB02FDCA06	41
ISB02FDCA08	41
ISB02FDCA10	41
ISB02FXCA06	41

CODE	PAGE	CODE	PAGE
ISB02FXCA08	41	ISB06HXCB06	40
ISB02FXCA10	41	ISB06HXCB08	40
ISB02HDCA06	40	ISB06HXCB10	40
ISB02HDCA08	40	ISB08FDCB06	41
ISB02HDCA10	40	ISB08FDCB08	41
ISB02HXCA06	40	ISB08FDCB10	41
ISB02HXCA08	40	ISB08FXCB06	41
ISB02HXCA10	40	ISB08FXCB08	41
ISB03FDCA06	41	ISB08FXCB10	41
ISB03FDCA08	41	ISB08HDCB06	40
ISB03FDCA10	41	ISB08HDCB08	40
ISB03FXCA06	41	ISB08HDCB10	40
ISB03FXCA08	41	ISB08HXCB06	40
ISB03FXCA10	41	ISB08HXCB08	40
ISB03HDCA06	40	ISB08HXCB10	40
ISB03HDCA08	40	ISCS02100	36
ISB03HDCA10	40	ISCS02100T	36
ISB03HXCA06	40	ISCS02101	36
ISB03HXCA08	40	ISCS02101T	36
ISB03HXCA10	40	ISCS02500	36
ISB04FDCA06	41	ISCS02500T	36
ISB04FDCA08	41	ISCS02501	36
ISB04FDCA10	41	ISCS02501T	36
ISB04FXCA06	41	ISCS04100	36
ISB04FXCA08	41	ISCS04100T	36
ISB04FXCA10	41	ISCS04101	36
ISB04HDCA06	40	ISCS04101T	36
ISB04HDCA08	40	ISCS041000T	36
ISB04HDCA10	40	ISCS041001T	36
ISB04HXCA06	40	ISCS04400	36
ISB04HXCA08	40	ISCS04401	36
ISB04HXCA10	40	ISCS06100	36
ISB06FDCB06	41	ISCS06100T	36
ISB06FDCB08	41	ISCS06101	36
ISB06FDCB10	41	ISCS06101T	36
ISB06FXCB06	41	ISCS061000T	36
ISB06FXCB08	41	ISCS061001T	36
ISB06FXCB10	41	ISCS06300	36
ISB06HDCB06	40	ISCS06301	36
ISB06HDCB08	40	ISCS10100T	36
ISB06HDCB10	40	ISCS10101T	36

Code index

CODE	PAGE
ISCS10200	36
ISCS10201	36
ISDS102	59
ISFIX00	7
ISFIX00B	7
ISFIX01	6
ISFIX01B	6
ISFIX01P	6
ISFIX01PB	6
ISFIX02	6
ISFIX02B	6
ISFIX02P	6
ISFIX02PB	6
ISFIX03	6
ISFIX03B	6
ISFIX03P	6
ISFIX03PB	6
ISFIX04	6
ISFIX04B	6
ISFIX04P	6
ISFIX04PB	6
ISFIX05	6
ISFIX05B	6
ISFIX05P	6
ISFIX05PB	6
ISFIX06	6
ISFIX06B	6
ISFIX06P	6
ISFIX06PB	6
ISFIX07	6
ISFIX07B	6
ISFIX07P	6
ISFIX07PB	6
ISFIX08	6
ISFIX08B	6
ISFIX08P	6
ISFIX08PB	6
ISFIX09	6
ISFIX09B	6
ISFIX09P	6
ISFIX09PB	6

CODE	PAGE
ISFIX10	6
ISFIX10B	6
ISFIX10P	6
ISFIX10PB	6
ISFIX11	6
ISFIX11B	6
ISFIX11P	6
ISFIX11PB	6
ISFIX12	6
ISFIX12B	6
ISFIX12P	6
ISFIX12PB	6
ISFIX13	6
ISFIX13B	6
ISFIX13P	6
ISFIX13PB	6
ISFIX14	6
ISFIX14B	6
ISFIX14P	6
ISFIX14PB	6
ISFIXG	7
ISFIXDAF	7
ISFIXVLO	7
ISKIT03	35
ISKIT04	35
ISKITYCO	35
ISPAN3F	17
ISPAN3M	17
ISPAN4F	23
ISPAN4M	23
ISPD1425G	48
ISPD14275	48
ISPD14440	48
ISPD1444G	48
ISPD14555	45
ISPD14556	45
ISPD14557	45
ISPD14558	45
ISPIN31525F	17,18,20
ISPIN31525M	17,18,20
ISPIN34060F	17,18,19,20,21

CODE	PAGE	CODE	PAGE
ISPIN34060M	17,18,19,20,21	MCM.3/VE/R	63
ISPIN44060F	23	MCT.1/SA/B	64
ISPIN44060M	23	MCT.1/SA/G	64
ISSAM05P	42	MCT.1/SA/R	64
ISSBM05P	42	MCT.2/SA/B	65
ISSCM05P	42	MCT.2/SA/G	65
ISSBM08P	42	MCT.2/SA/R	65
ISSCM08P	42	MCT.3/SA/B	65
ISVOL3F	18	MCT.3/SA/G	65
ISVOL3FGPGC	20	MCT.3/SA/R	65
ISVOL3FGPGL	21	MI0100	49.50
ISVOL3GF	19	MI0200	49.50
ISVOL3GFL	19	MI0300	49.50
ISVOL3GM	19	MI0400	49.50
ISVOL3GML	19	MIAL40	49.50
ISVOL3M	18	MIZS20	49.50
ISVOL3MGPGC	20	NU0851	57
ISVOL3MGPGL	21	NU1051	57
ISVOL4F	23	PR003	57
ISVOL4M	23	PR005	57
MC401B	63	PV1-F	38
MC401G	63	QBLOK2100	56
MC401R	63	QBLOK2125	56
MC402B	64	QBLOK2126	56
MC402G	64	SF903GR	59
MC402R	64	TO120	52
MC403B	64	TO220	52
MC403G	64	TO320	52
MC403R	64	TO430	52
MCM.1/B	61	TO510	52
MCM.1/G	61	TO810	52
MCM.1/R	61	TO910	52
MCM.2/B	62	UMCT	34
MCM.2/G	62	UMCT3127	32
MCM.2/R	62	UMCT3128	32
MCM.3/B	62	UMCT3129	32
MCM.3/G	62	UMCT3149	14,17,18,19,20,21,23,27,28,29 31,32,35
MCM.3/R	62	UMCT3153	28
MCM.3/VE/B	63	UMCT3154	28
MCM.3/VE/G	63		